

PianoDisc

LPS

**Installation Manual for the
*PianoDisc Low Profile System***

Version 1.6

PianoDisc
4111 North Freeway Blvd.
Sacramento, Ca. 95834
www.pianodisc.com
(916) 567-9999 Fax (916)567-1941

TABLE OF CONTENTS

Table of Contents.....	Page 2
Introductory	Page 3
Step 1 - Disassemble the Piano.....	Page 4
Step - Remove the Keybed.....	Page 10
Step 3 – Measure the back key spacing for key solenoids.....	Page 13
Step 4 – Take keyframe measurements.....	Page 18
Step 5 – Create back rail bead on keyframe in necessary.....	Page 20
Step 6 – Cut the keyframe.....	Page 21
Step 7 – Mark the location of the solenoid rail slot.....	page 23
Step 8 – Prepare to cut the solenoid slot.....	Page 27
Step 9 – Cut the solenoid slot.....	Page 27
Step 10 – Reinforce the keybed.....	Page 31
Step 11 – Cut leg slot to fit solenoid slot.....	Page 31
Step 12 – Assemble tray, solenoid rails and guide solenoids.....	Page 33
Step 13– Installing the trapwork.....	Page 37
Step 14 – Adjusting the key solenoid rails.....	Page 56
Step 15 - Install Key Solenoid.....	Page 58
Step 16 – Assemble driver boards to the solenoid tray.....	Page 61
Step 17 – Setup for burn in.....	Page 64
Step 18 – Burn in Unit.....	Page 66
Step 19 – Install driver boards into tray assembly.....	Page 66
Step 20 – Drill hole in belly rail for wires.....	Page 67
Step 21 – Mount the CPU.....	Page 68
Step 22 – Mount the power supply.....	Page 68
Step 23 – Mount the power strip.....	Page 68
Step 24 – Mounting keybed to the piano.....	Page 70
Step 25 – Regulate action.....	Page 70
Step 26 – Set the height of the adjustable plungers.....	Page 71
Step 27 – Set up communication with the PianoDisc system.....	Page 72
Step 28 – Adjust the pedal solenoid.....	Page 72
Step 29 – Finale check list.....	Page 74
Step 30 – Ground strap installation.....	Page 74
Addendum 1 – Steinway Sostenuto.....	Page 76
Addendum 2 – Keyframe modifications/shift lever.....	Page 79
Addendum 3 – Clearance for end plates.....	Page 79

Low Profile PianoDisc Installation Manual

This installation manual will guide you through the process of fitting a PianoDisc reproducing piano system to virtually any grand piano. Along with the knowledge and experience gained from a PianoDisc Installation Seminar, this guide should be an invaluable resource.

Information contained in this manual is considered confidential by PianoDisc, and is for the sole use of PianoDisc Certified Technicians. It may not be reproduced, distributed or quoted in whole or in part without the express written permission of PianoDisc.

The installation instructions in this guide pertain only to the PianoDisc Low Profile Reproducing System. PianoDisc Reproducing Systems may ONLY be installed by technicians certified by PianoDisc as qualified to perform such installations. If you have come into possession of this manual and / or a Retrofit Kit and you are not a PianoDisc Certified Technician, DO NOT ATTEMPT TO PERFORM THIS INSTALLATION.

Installations not performed by a certified PianoDisc technician WILL NOT meet the requirements for warranty protection from PianoDisc and likely such an installation would also void the piano manufacturer's warranty. Installation mistakes may cause violations of FCC regulations that could result in an enforcement action by the FCC.

Technicians may be certified by attending a PianoDisc Installation Seminar. Another option for the technician is by attending an onsite training evaluation and certification class conducted by a PianoDisc Factory Installation Technician duly authorized to certify technicians.

A candidate for PianoDisc certification should be a Registered Piano Technician (RPT) and thus certified by the Piano Technicians Guild (PTG). A candidate who does not qualify under this rule will be evaluated on an individual basis with emphasis on total experience as a piano technician and possible previous experience in retrofitting pianos with other player piano mechanisms.

In the interest of continuous improvement, we encourage piano technicians to comment on this installation manual by writing to:

Piano Disc
4111 North Freeway Boulevard
Sacramento, CA 95834

You may also fax your comments to PianoDisc at this number. (916) 567-1941.

Technical support for PianoDisc Certified Technicians is available Monday through Friday, 8AM to Noon and 1PM to 5PM Pacific Time at (916) 567-9999.

1. Disassemble the piano

NOTE: Text in **BLUE** refers to keybeds that are removed from the piano.

A. Inspect the piano

- While the mover is still present, inspect the piano thoroughly pointing out any damage.
- It is also important record the damage on an inspection sheet and take pictures if possible.

B. Remove the music desk, fallboard and keyslip from the piano.

- The music desk is easy to remove as it will typically just slide or lift out of the piano. It is a good idea to carefully place all case parts so they will not be damaged while the piano is being worked on.
- Some keyslips are held down by a wedge between the keyslip and the keyblocks. To remove this type of keyslip, remove the screws holding the keyblocks down against the keybed. Often there is a folding wing nut on the bottom of the keybed making this type of keyblock quite easy to remove. If the fallboard is not mounted on the keyblock remove the keyblocks from the piano and then remove the keyslip.

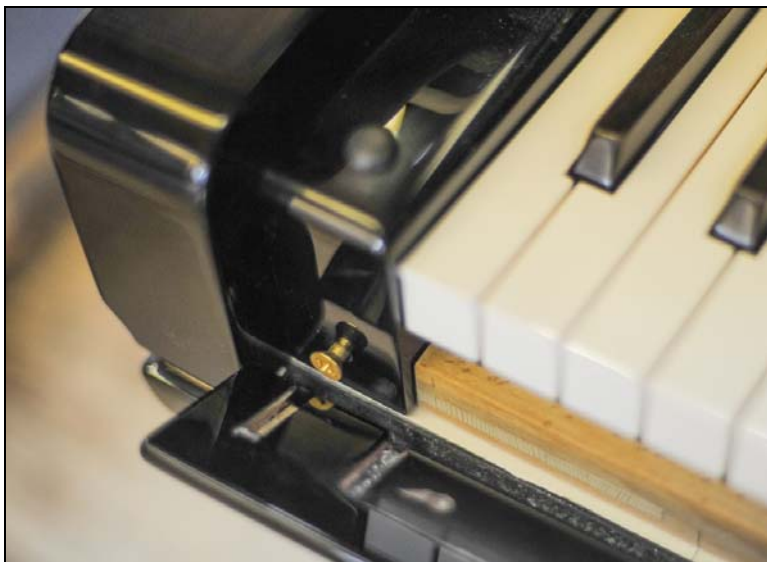

Illustration 1 – Keyslip & screw

- Another type of keyslip is designed with a slot in the back side of the keyslip that slides friction tight over a hidden screw in the end of the keyblock. On this style the keyslip will slide up and off the screw head in the end of the keyblocks. (See Ill. 1)

- Some fallboards are attached to the cheek blocks at each end of the keyboard. On this style the screws holding the cheek blocks must first be removed. Typically the screw is found directly underneath on the keybed. After the fasteners are removed, the fallboard and keyblocks are
- Removed as a unit. Be careful as the keylocks often come off the fallboard easily when the piano no longer prevents them from doing so. If the keylock were to fall to the floor, damage can occur.
- Some keyslips are attached to the keybed with screws. The screw heads are found on the bottom of the keybed. Remove the screws and lift the keyslip out of the piano.

C. Mark the location of the keyframe on the keybed.

- Make sure that during removal of the fallboard and keyblocks, the keyframe has not moved. If there is any doubt, put the keyblocks back into place and use the keyframe guides in the keyblock to position the action correctly. Gently remove the keyblocks being careful to not move the action. Draw a line around the keyframe on the keybed. This will help you place the keyframe correctly later in the process.



Illustration 2 - Marking front of keyframe

- Make side to side marks on the front rail to aid in positioning the keyframe later in the process. Get a piece of wood (anything will do) 1 (25mm) to 2 (50mm) inches square with a square end. (See Ill. 2) Mark 3 positioning lines between the front rail and the keybed equally spaced across the keyframe. Place the piece of wood against both the front rail and the keybed. Without moving the block of wood, use a scribe to mark a line on both the front rail and the keybed. These positioning lines will ensure that you will be able to place the action side to side later in the process.



Illustration 3 - Marking side of keyframe

- Make front to back marks between the end of the keyframe and the keybed. These marks will help you position the keyframe accurately front to back later in the process. Remove the keyblocks without moving the keyframe. Using the same process as on the front rail, place the block of wood against both the keybed and the keyframe and make alignment marks for front to back positioning using a sharp pencil. Do this at both ends of the keyboard. (See Ill. 3)
- You now have the ability to easily position the keyframe on the keybed whenever that is needed during the process of installing a PianoDisc system in this piano.

D. Measure key height.



Illustration 4 - Measuring key height - front

E. Front Key Height.

- Key height is an important measurement that must be taken at this point. (See Ill. 4)

- Later you will need to set the height of the keys back to their original height.
- Use a ruler to measure from the top of the keytop to the top of the keybed.

F. Remove the action from the action cavity.

- With your hand vertical and the guide pins between your fingers, pull the action from the action cavity and place it on a workbench.
- Be careful, it is easy to damage the action with this operation. If your hand depresses either end key to any extent at all it will cause the corresponding hammer to rise. When you pull the action forward the hammer will catch on the plate or pinblock, likely breaking either a hammer shank or worse, a hammer.
- If the piano arrives at your workshop on its side the action is nearly impossible to remove because the hammers are rotated up from the rest cushions. To solve this, you will need to tilt the piano in order to remove the action from the piano.
- New pianos shipped in a crate usually have the hammers tied down. If this is the case you can remove the action from the action compartment while the piano is still on its side.

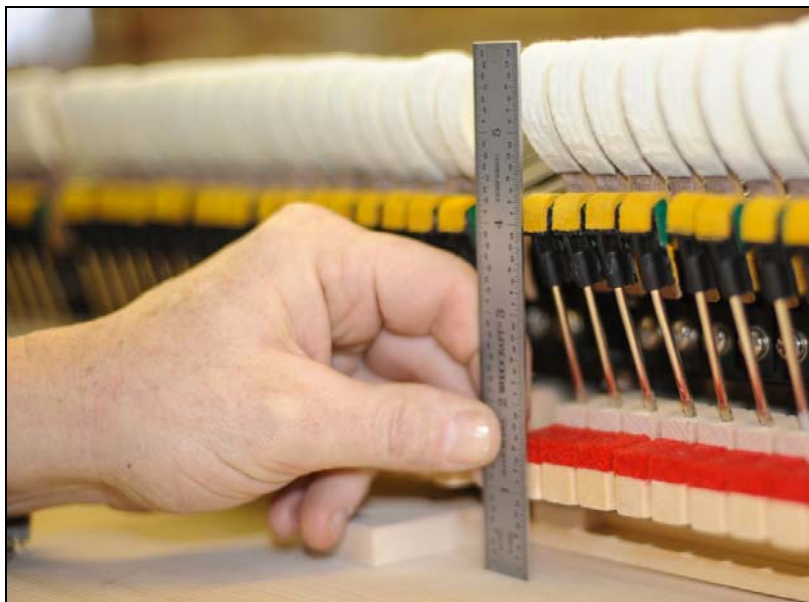

Illustration 5 - Measuring key height – back

G. Back Key Height.

- You will need this measurement later on to calculate the length of the solenoid.
- Use a ruler to measure the distance between the bottom of the key and the keybed. Do this at the end of each section of the piano. Likely you will see variance in these numbers. (See Ill. 5)

- When you set up level and dip for the keyboard after the PD installation you will need to set a spec for the back key height and then hold it.



Illustration 6 - Sostenuto hook

H. Mark the left/right location of the sostenuto hook on the keybed.

- Disconnect the sostenuto pitman from the sostenuto hook.
- Use a 6" (15cm) rule to find the center of the sostenuto hook.
- With the square transfer this mark to the keybed. (See Ill. 6)

I. Lid removal.

- It is optional as to whether or not you remove the lid.
- Tape the hinge pins to the appropriate hinge to ensure that the hinge pins do not get lost during the installation.
- If you remove the lid, as with the other case parts, store in a safe location and in a safe manner so no damage will result.
- If you leave the lid on the piano secure the lid with a rubber band so it cannot fall.



Illustration 7 - Piano on side

J. Place the piano on its side.

- At this point, place the piano on a skid.



Illustration 8 - Leg locations on keyed

K. Mark leg locations on the keyed and legs.

- With the piano on its side, use a soft lead pencil to draw the outline of the left and right (in piano speak bass and treble) legs.
- On the top of each leg mark the location on the piano. (See Ill. 8)
 - Customarily, the bass keyed leg is #1, the treble keyed leg is #2 and the leg under the bass bridge is #3.
- This information will be indispensable later when portions of the legs will likely be cut away.

2. Remove the keybed (if possible).

A. Determine if keybed removal is possible.

- If possible, the job of installing a PianoDisc system is much easier if the piano allows you to remove the keybed from the instrument.
- Many, but by no means all, newer pianos allow removal of the keybed. A number of older pianos, as well as all Steinway pianos, do not.

B. Check Appendix A of this manual.

- Appendix A of this manual contains a list of piano makes with easily removable keybeds.
- While PianoDisc has tried to help you out here, this list cannot possibly be all inclusive.
- However, if the piano you are working on is not on the list the keybed may still be removable.

C. If in doubt, check to see if the keybed is glued onto the rim and belly rail.

- If the keybed is not glued to the rim and belly rail you will be able to remove the keybed.
- If you find that the keybed is removable do so. Otherwise you will be working inside the action compartment rather than on the bench. On the bench is much more convenient and sensible if possible.

D. Set up locating pins for the keybed.

- Check to see if the manufacturer included position pins. (See Ill. 9)
 - It is important to get the keybed back to its original location.
 - Also, with the pins in place, it is much easier to remove and install the keybed.
 - When you remove the keybed screws the locating pins will keep the keybed from falling until you are ready to physically move the keybed to a bench.



Illustration 9 - M&H locating pin



Illustration 10 - WNG stainless steel locating pin

- Sometimes the manufacturer's position pins are inadequate or were not used.
 - Sometimes the original pins are flimsy. If this is the case or the manufacture failed to provide position pins you will need to install pins of your own choosing for the installation of the PianoDisc system.
 - You will find that a sturdy, good quality position pin will help with keybed removal and, later, keybed re-installation.
- To install pins PianoDisc recommends the WNG stainless steel positioning pin. (See Ill. 10)

- This pin has a diameter of 5/16" (8mm), a length of 3" (75mm) long and is tapered at both ends.
- The pin is sturdy and because it is made from stainless steel will not corrode.
- Mark for two locating pins.
 - There should be a pin on each side of the piano far enough apart to adequately locate a keybed.
 - PianoDisc prefers location pins centered in the belly rail however at the end of the arms will also work well.
- Note: Drilling the holes for the locating pins is a two-step process. The hole in the rim or the belly rail needs to be an interference fit, that is, the hole should be smaller than the pin by about 1/64" (.4mm). The hole in the keybed should be larger than the hole in the rim or belly rail, about the actual size of the pin.



Illustration 11 - Wood drill guide

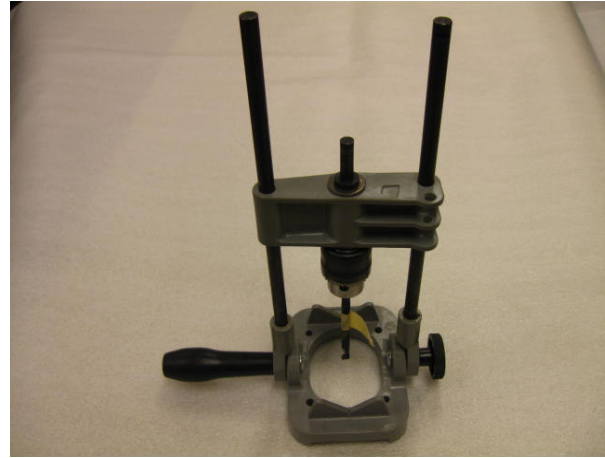

Illustration 12 – Store bought drill guide

- Drill the hole in the rim or belly rail.
 - Choose a drill bit about 1/64" (.4mm) smaller than the pin you intend to use.
 - Drill through the keybed so that the hole in the belly rail or rim is about 1-1/2" (40mm) deep.
 - Make sure you drill in a true vertical to the keybed surface because angled pins will make your life quite difficult when removing and re-installing the keybed.
 - Use a drill guide to drill a straight hole. (See Ill. 11 and 12)
- Drill the clearance hole in the keybed.
 - Measure the thickness of the keybed.
 - Select a drill bit as close to the actual size of the locating pin as you can.
 - Tape a flag on the drill bit so that the depth you drill corresponds to the thickness of the keybed.
 - Again, be sure you drill in a true vertical fashion to follow the original hole you drilled into the belly rail or rim.
- Drive the location pin into the hole until it is flush with the keybed.
 - When pounding in a locating pin it is important to not mushroom the head of the pin.
 - To this end use a hammer that is softer than the pin.
 - A good choice is a brass or plastic hammer.

E. Remove the keybed.

- Prepare saw horses, or some other support, on which to put the keybed after you remove it from the piano.
- Remember that the edges of the keybed are finished so care is in order.
- Remove the screws holding the keybed onto the piano.
- Lift the keybed off the locating pins and place the keybed onto supports upside down.



Illustration 13 - Belly rail with pin

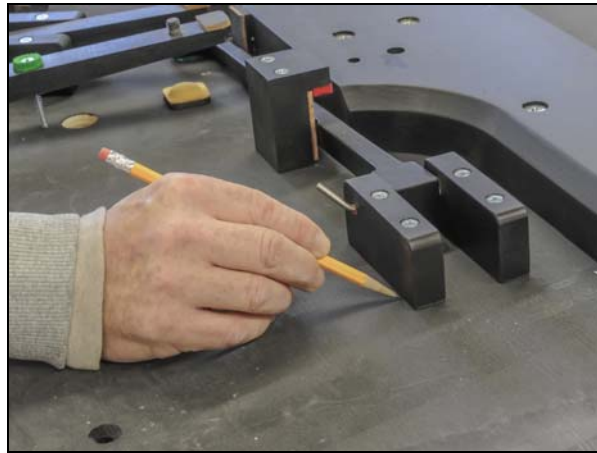

Illustration 14 - Mark shift lever blocks on keybed

F. Mark the location of the shift lever support blocks on the keybed.

- Draw a line around the blocks that support the shift lever. Later on you will use these lines to decide if you need to move the pedal lyre forward. (See Ill. 14)

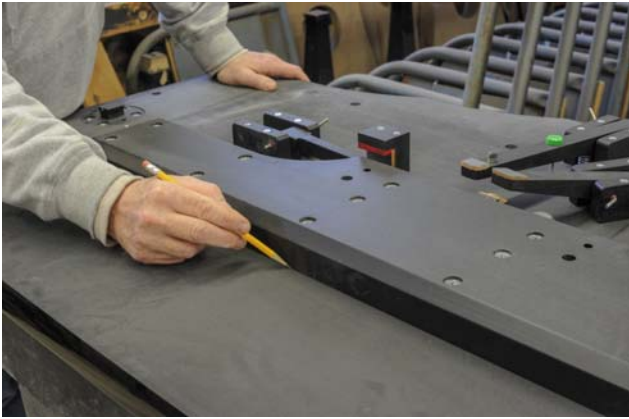

Illustration 15 - Draw line around keyboard log



Illustration 16 - Mark Sostenuto pitman hole

G. Mark the location of the keyboard log on the keyboard.

- Draw a line around the keyboard log on the keyboard. This will allow you to move the lyre and keyboard log a specific distance forward later on if needed. (See Ill. 15)

H. Remove trapwork.

- Remove all pedal trapwork from the bottom of the keyboard.
- Mark a line 3" (76mm) forward from the center of the shift lever hole as a reference. Be very accurate with this measurement. At the 3" (76mm) location place an intersecting line. (See Ill. 16)
 - This is an important step as the hole for the shift lever may be removed by the key solenoid slot cut.

I. Measure and mark Sostenuto pitman hole on the keyboard.

- Draw a line perpendicular to the front of the keyboard through the center of the sostenuto pitman hole for future reference. It is best to place this reference line on the bottom of the keyboard.
- It is not necessary to reference the location of the sustain hole as this will be determined by the sustain pedal solenoid location later.

J. Remove the action stack from the keyboard.

- Place the top action and screws in a safe place.

3. Measure for key access

A. Determine if you must omit key solenoids.

- Typically, at the high and low ends of the piano, the PianoDisc unit will extend under the legs. To create the necessary room, some portion of the leg is cut away. Sometimes the customer objects or perhaps there are very high value custom art case legs. For whatever reason, if you are not able to cut the legs down for room, then you will need to omit key solenoids. It is no problem to drop 2 or 3 solenoids at each end of the piano. You will need to measure how far the leg protrudes under the keys and drop solenoids accordingly so that the slot the PianoDisc system is installed into no longer extends under the legs.

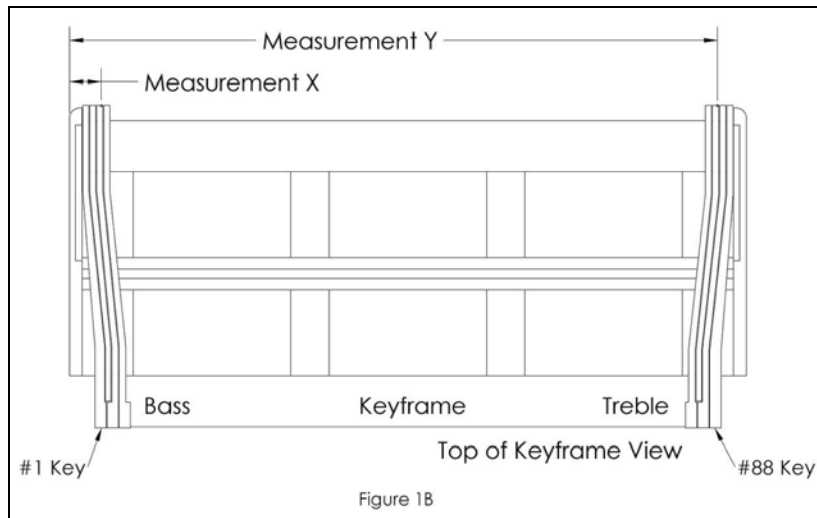
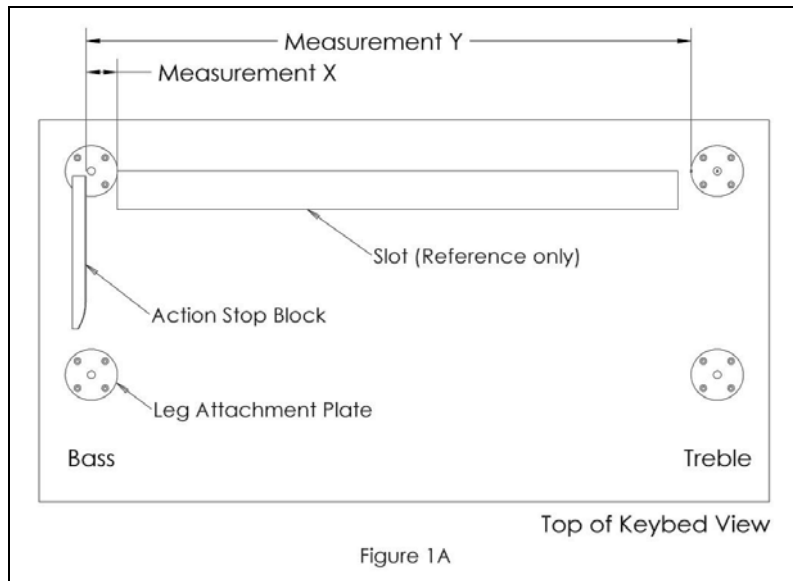

- Sometimes the leg mounting system doesn't allow removal of material from the legs. A number of pianos attach the legs to the keybed with bolts that go through the leg top into metal plates embedded into the keybed. These plates cannot fall in the slot for solenoids otherwise you will lose one of the legs attachment points. In this case you will need to omit solenoids so as to keep the slot for the PianoDisc unit safely inside the leg mounting points.
- Use the following steps to determine your course of action.

In the piano

- Measure from the Action Stop Block to the treble side of the Leg Bolt Plate. This measurement should be taken parallel to the front of the keybed. This is measurement "X" in Figure 1A. Transfer this measurement to the keyframe. See Figure 1B.

- Measure from the Action Stop Block to the bass side of the treble Leg Bolt Plate. Again this measurement should be taken parallel to the front of the keybed. This is measurement “Y” in Figure 1A. Transfer this measurement to the keyframe. See Figure 1B.

NOTE: There must be 5/8” (16mm) from the side of the end key to the end of the solenoid slot for access.

Keybed off the piano

- Mark a line on the keybed at each end of the slot due to leg plates or legs that are not to be cut for access to the keys.
 - Place the keyframe on the keybed at the locating marks made earlier in step 1-C.
 - Mark the keyframe for the number of notes that will be left off each end of the solenoid tray.

B. Making the key stick.

- At the front of the keys notes are evenly spaced from left (bass) to right (treble). Typically notes are numbered starting at 1 in the bass to 88 in the treble.

Note: There are pianos that have more than 88 notes but the PianoDisc system only recognizes 1 - 88.



Illustration 17 - action Sections

- The back of the keys are divided into sections that correspond to plate bars in the piano. Often, but not always, there will be 4 sections. The bass is group 1, the tenor is group 2 (sometimes there are two tenor sections), the low treble is group 3 and the high treble is group 4. The spaces between these groups are referred to as breaks.

C. Decide how to deal with sections that have an odd number of notes.



Illustration 18 – PD Old PD systems

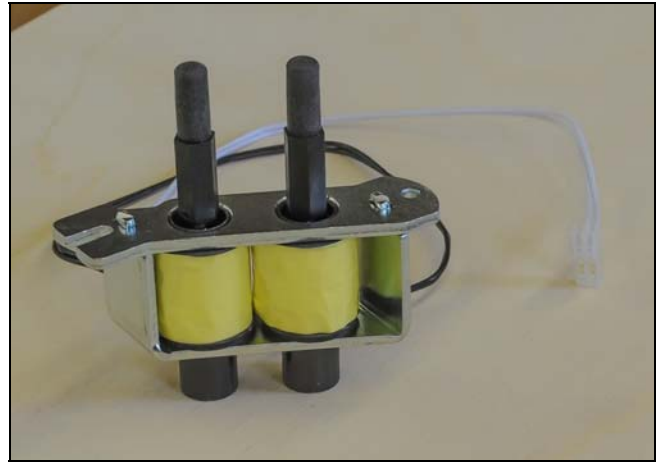

Illustration 19 – PD new low profile solenoid

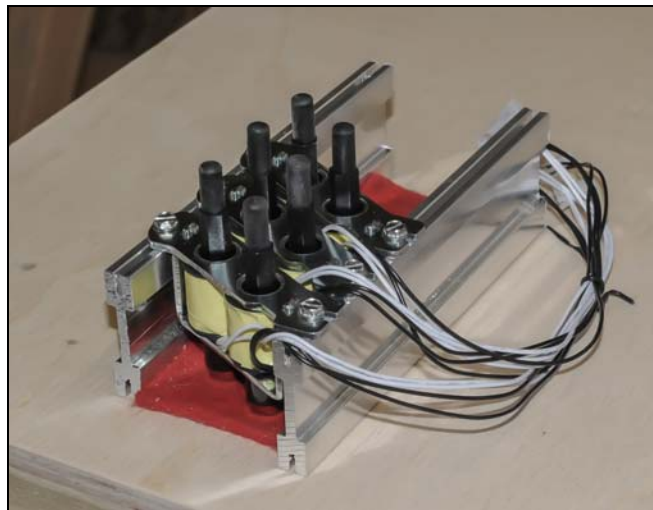

Illustration 20 – PD low profile solenoid rail systems

- There are important differences between the new Low Profile PianoDisc System and the old. The new system has two rows of solenoids instead of one. The row closest to the capstans is referred to as front. The row closest to the end of the keys is referred to as back.
- Each solenoid bracket assembly mounts two solenoids. The bracket is designed so one end mounts on the front mounting rail and the other mounts on the back mounting rail. The bracket positions the solenoids in two rows between the two mounting rails.
- The bracket is designed to be mounted at an angle so that the solenoid on the front rail falls under one key and the solenoid on the back rail falls under the next note higher in the piano. It is not possible to mount the bracket at the opposite angle.
- An important consideration to keep in mind is that it is important to keep the length of the slot in the keybed as short as possible. Among other reasons this minimizes the clearance cuts in the legs that will be required. To this end, solenoid bracket assemblies need to be mounted so that the end solenoid falls on the end key at the top and bottom of the scale.

- At the lowest note in the piano, usually note #1, numbering schemes can differ, this presents no problem as the solenoid for note 1 is the front solenoid and the solenoid for note 2 is on the back solenoid. All you need do is mount the bracket at the appropriate angle and everything will work.
- At note 88, if there is an even number of notes in the section, there will be no problem as the last solenoid (the back solenoid) will fall on note 88.
- If you have omitted solenoids then the highest and lowest note numbers are where you will need to start numbering for the PD system.
- Not all sections have an even number of notes. If the note count is not even then the approach needs to be different. There are no single solenoid brackets, they all provide two solenoids. This means that in a section with an odd number of notes there will be one extra solenoid. If the front solenoid were to fall on note 88 the extra solenoid would fall on the non-existent note 89. This would require extra room in the slot and more material removed from the leg. While the system would likely work this is not a good idea.



Illustration 21 - extra solenoid in break

NOTE: Picture above is ONLY for a reference – DO NOT assemble solenoid rails until instructed.

- It is better to match solenoids to keys in the high treble starting from note 88 and working down in the section. The extra solenoid will then fall in the break between the low treble and high treble. It is ok to have a back solenoid on say note 72 and a front solenoid in the break. (See Ill. Above) Customarily, for any solenoid that will not operate a note you will simply cut the wire and remove the plunger. The kit will always provide spares so there will always be enough.
- Count the notes in each section. For those sections with an odd number of notes, decide where the extra solenoids will be placed. Once you have made these decisions you are ready to make a key scale stick.

D. Make a scale stick from the back of the keys.

- You will need a stick of wood that is about 2" (50mm) longer than the distance from the outside of note 1 to the outside of note 88. This stick should be about ¼" (6mm) thick. The dimensions for length and thickness do not need to be precise.
- The width of the key scale stick should be 9/16" (14mm) because this is the available space between the solenoid rows when the diameter of the stems is taken into account. It is important to be reasonably accurate when cutting the width of the key scale stick otherwise there will not be ample room to space the solenoids apart.

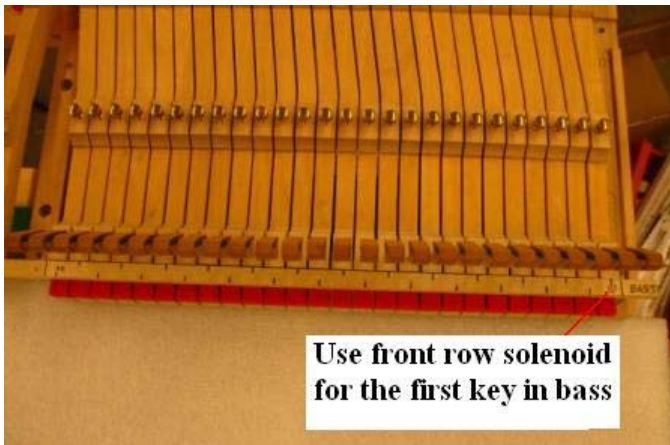

Illustration 22 - Marking scale stick

- Place the blank key scale stick on the back of the key approximately 3/8" (10mm) in from the back of the key. Tape the strip onto the keys so it is not able to move. Mark the bass end of the key scale stick so you do not accidentally set up the solenoids backwards later.
- Mark the strip with a sharp pencil, on alternating sides, where the scale stick intersects the center of the key. Start at note 1 in the bass. Remember that when working on the back of the keys the bass keys are to your right. Mark note 1 on the front side of the strip, mark note 2 on the back side of the strip. If you have odd numbered sections mark from the end with no spare. Mark all 88 notes in the piano in this fashion.

4. Measuring for keyframe cut

A. Remove the keys from the keyframe.

- Remove all keys from the keyframe except the end keys in each section.
- It is best to store them in order 1 to 88 as it makes re-assembly much easier.
- If the numbers on the keys are not easy to read re-number the keys with a ball point pen behind the capstans so that the numbers do not show after the action is attached to the keyboard.



Illustration 23 – Marking keyframe cut location



Illustration 24 – Using tape for cut line

NOTE: When measuring to cut the key rest felt, if most of the felt will be cut away or there is no loose felt, just the glued on portion then you should carefully remove the felt and re-locate forward to the cut line. It will be necessary to re-level keys later.

B. Mark the back rail cloth for the keyframe cut.

- Measure from the end of the first and last key in each section 1.5" (40mm) towards the front of the key.
- Mark this point on the keyframe felt with a permanent black marker.
- This dimension will leave the keyframe hanging over the slot by about 11/16" (18mm).
- The clearance from the keyframe to the solenoid row will be about 3/8" (10mm).
- The purpose of this approach is to preserve as much of the keyframe as possible.
- Mark a straight line from the points with a straight edge and a permanent black marker.
- Use a lid rubber band to secure the balance and front rail punchings from falling off while the keyframe is inverted.
 - Weave the rubber band thru the front and balance rail pins for this purpose.

C. Mark the bottom of the back rail for the keyframe cut.

NOTE: The purpose of marking the keyframe cut line on the bottom of the keyframe is to see if there is support or not. The keyframe is cut from the top side.



Illustration 25 - Bottom of keyframe measurements

- Turn the keyframe upside down.
- Measure, from the end of the #1 and #88 keys, towards the front of the keys 1.5" (40mm) and mark on the bottom of the keyframe.
- This is the keyframe cut line.

NOTE: If less than 2" (50mm) width of rest rail is left after keyframe cut it is recommended that some reinforcement be added to the front of the rest rail before cutting the keyframe.

- Measure, from the end of the #1 and #88 keys, towards the front of the keys 2-5/16" (58mm).
- Mark this dimension on the bottom of the keyframe for the bead or keyframe support.
- Draw a line the length of the keyframe from key 1 to 88.
- This line represents the front of the keybed slot.

NOTE: It may be necessary extend the shift lever contact point on the keyframe. (See III. In appendix)

D. Determine if the back rail needs additional support after it is cut back to the required dimension.



Illustration 26 – Keyframe without support bead



Illustration 27 – Iron-on veneer shim

- Customarily, the bottom side of a keyframe is recessed by 1/8" (3mm) or so except for a relatively narrow strip on the front rail and on the back rail.

- This narrow strip is called the bead.
- When the keyframe is cut back for PianoDisc installation this bead may be either too small or entirely removed leaving no support for the back rail on the keybed.
- If this is the case you will need to recreate the bead further in on the back rail.
- Measure the height of the old bead with calipers.
- Some pianos also have recessed areas in the keybed that needs to be taken into account. Kawai is a perfect example of a recessed keybed.
- If this is so then it would be important to shim the keybed flush 1" (25mm) in front of the keybed cut line for proper support before cutting the slot.

5. Create back rail bead on keyframe if required.

A. Prepare the shim

- There are a few different methods of replacing the bead or support.
 - Clear pine or softwood molding in a continuous 1" (25mm) wide strip. (See Ill. 30)
 - Place 5 – 1" (25mm) x 2" (50mm) pieces of softwood equally spaced on the keyframe.
 - Iron-on veneer in a continuous strip or 5 – 1" (25mm) x 2" (50mm) pieces equally spaced. (See Ill. 28 and 29)
 - The iron-on veneer comes with self adhesive which can be ironed on activating the glue.



Illustration 28 – Iron on veneer



Illustration 29 - Ironing on veneer

B. Glue the shim onto the keyframe.

- Apply a thin coat of a good quality structural wood glue.
 - In the United States "Titebond" is a brand name sold by Franklin that would be a good example.
- Apply glue to the new bead and clamp it to the keyframe.
 - Usually a number of spring clamps will do this job quite well.
 - Allow the glue to dry for about 1 hour.
 - Sand the shim to the correct height.



Illustration 30 - Back rail shim, soft wood



Illustration 31 – Installing support on Kawai

C. Kawai Keybeds

- Kawai pianos have a keybed cutout or recessed areas as you can see in Ill. 31. The best way to fix this is to build up the area for the new bead so there is a level contact surface.
 - Glue 1" shim stock of the appropriate thickness in the 2 cutout areas and sand flat after drying.

6. Cut the keyframe.

NOTE: Because of moving the shift lever forward it is important to check the contact area on the keyframe. Please see the Addendum 2 on page 79 at the end of this manual.

A. Cut the back rail cloth.

- The back rail cloth needs to be cut back prior to cutting the back rail if needed.
- Use a sharp knife or razor blade to cut the line you marked on the back rail cloth earlier.

B. Cut the back rail.

- Use a jig saw to cut the keyframe to the line previously marked.
- Remember, the keyframe will hang over the slot so that it is 3/8" (10mm) from the center line of the front row of solenoids.



Illustration 32 - cleats extending behind the back rail

C. Caution:

- You need to remove the back rail between the action cleats.
- Make sure you do not cut the action cleats.

D. Remove the keybed log.



Illustration 33 - Log removed



Illustration 34 - Keybed on bench

E. Turn keybed over so top side is up.

- Once the keybed log is removed turn the keybed over so the top side is up.
- You are now ready to measure the solenoid slot location.

F. Remove the dag blocks.



Illustration 35 - Remove dag screws



Illustration 36 - Knock off dag

- The “Dag” blocks hold the back of the action down.
- Usually they fall in the slot.
- Therefore, the dag blocks need to be removed.
- Remove all screws that hold the dag blocks down.
- Use a chisel or wood block to knock the dag blocks off the keybed.

7. Mark the location for the solenoid slot

Note: Marking the starting location for the solenoid slot is the same whether the keybed comes off or not.

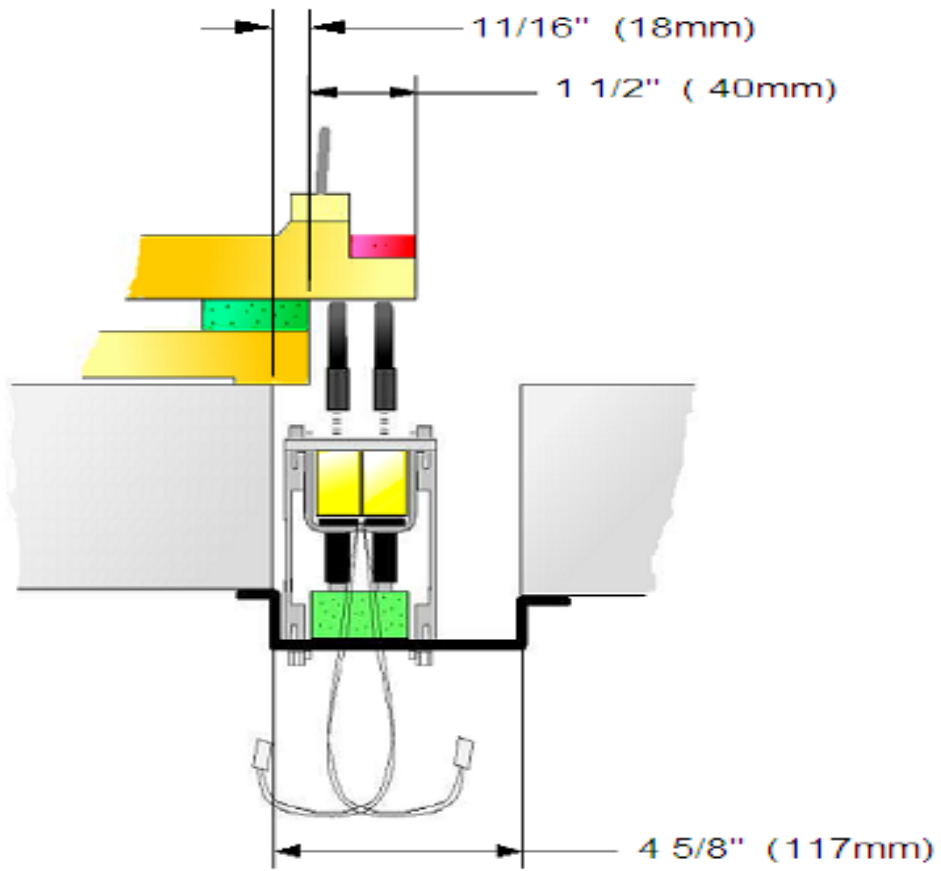

Illustration 37 - Side view of tray assembly, keyed and action

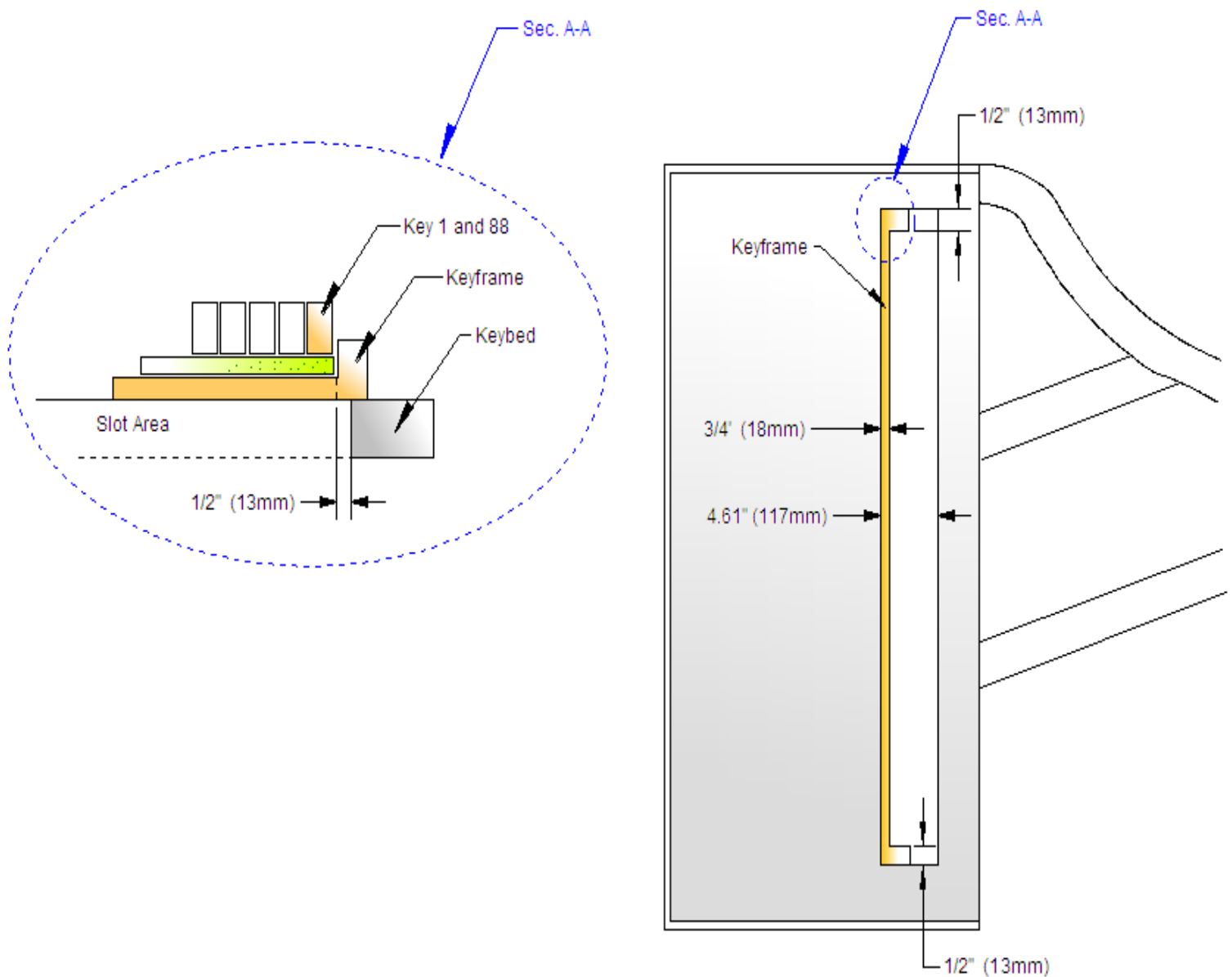

Illustration 38 - Bottom side of slot and keyframe dimension

A. For pianos with the keybed removed.

- Place the keyframe on the keybed and line up the marks made in 1-C. (Also see Ill. 39)
- Mark the keybed at the keyframe cut on the bass and treble ends. (See Ill. 40)

Note: If you have the Slot locating tool, this would be a good time to use and save some time. (See Ill. 43 and 44 on page 26).

- Mark the front keybed cut line.
 - Remove the keyframe.
 - Measure 11/16" (18mm) toward the front of the keybed to establish the front solenoid cut line. Do this at both the bass and treble ends. (See Ill. 41)

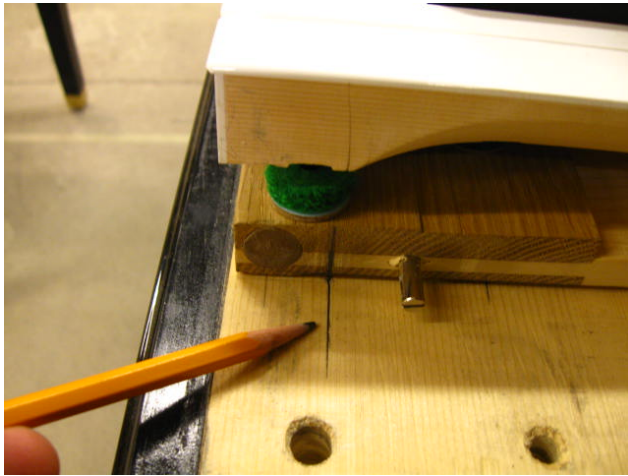

Illustration 39 - Keyframe located on marks



Illustration 40 - marking keyframe cut on keybed

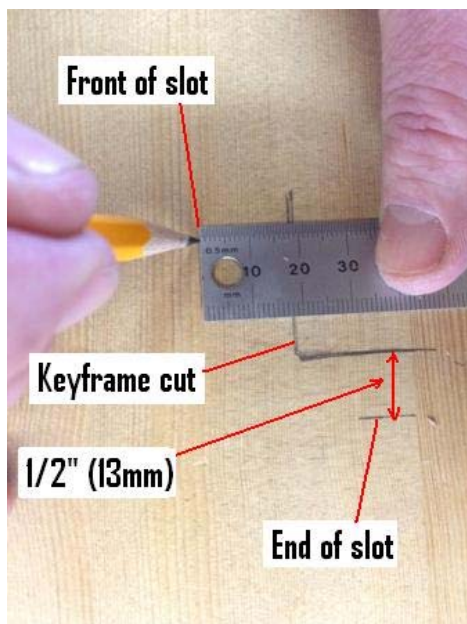

Illustration 41 - Marking front slot location

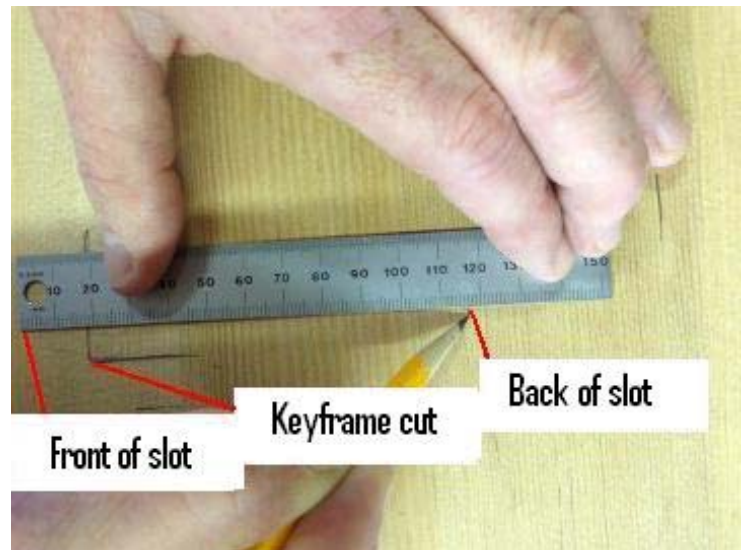
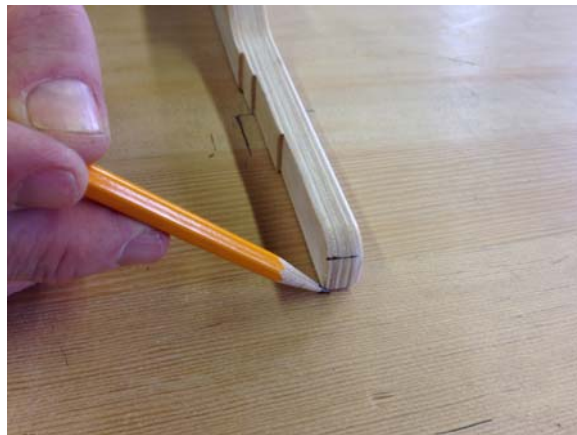
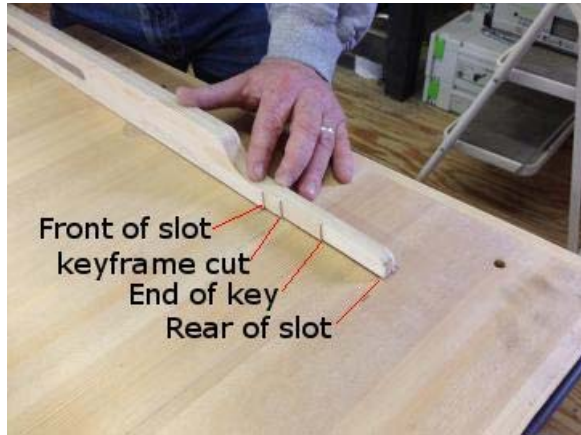

Illustration 42 – Marking back slot location

- Now measure 4-5/8" (117mm) to the rear of the piano to establish the back of the solenoid slot. Do this at both the bass and treble ends. (See Ill. 42)
- Connect both the front and rear solenoid slot lines. (See Ill. 45 and 46)
- Using the Slot locating tool to locate the slot.
 - Place the keybed square against the edge of the keybed.
 - Align the slide with the end of keyframe mark. (See Ill. 43 and 44)
 - Loosen the wing nut and slide the slot marking slide so that the correct notch corresponds with the keyframe mark you made on the keybed. (See Ill. 43)
 - Tighten the wing nut to hold this measurement.
 - With a pencil, mark the keybed on the notches that define the back side and the front of the slot.

- Do this measurement for both the treble and bass locations.
 - Locating the end of the slot
 - From the end of keyframe mark on the keybed, add ½" (13mm) for additional room for the key solenoids. Do this for the bass and treble ends to establish the end of the slot. (see Ill. 47)
- Note: If you need to drop more solenoids repeat step 3-A to define the top and bottom notes for the PianoDisc system and correct the scale stick.
- Make sure these marks are accurate as you will use these marks to define the front to back and end dimensions for the slot you will cut in the keybed.



Illustrations 43 & 44 - Slot marking tool



Illustration 45 - Marking front line for slot



Illustration 46 - Marking back line for slot

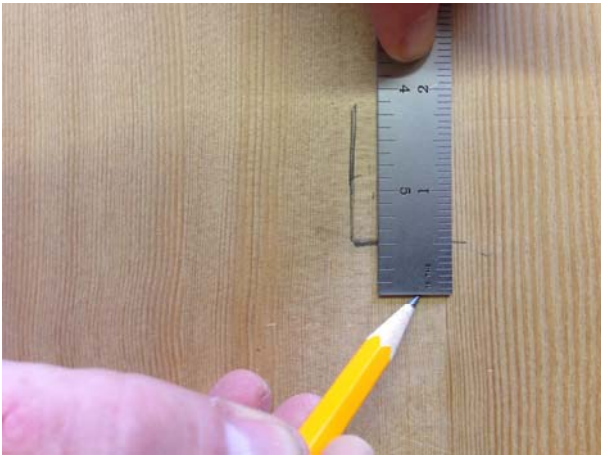

Illustration 47 - Marking end of slot



Illustration 48- Marking end slot cut

- Place the keyframe in the piano with the end blocks in place.
 - Mark a pencil line along the back edge of the keyframe cut. (See Ill. 40)
 - Do this on the bass and treble ends only including the end cut of the keyframe.
 - Make sure these marks are accurate as you will use these marks to define the front to back dimensions for the slot you will cut in the keybed.
 - Remove the keyframe.
 - Transfer the keyframe line to the bottom side of the keybed.
- NOTE: If you have the slot marking tool, this is a good time to use it.**
 - Use the Slot marking tool to locate the slot.
 - Place the slot marking tool inside the piano with the keybed square against the edge of the keybed at the treble end. (see Ill. 43)
 - Align the slide with the end of keyframe mark.
 - Loosen the wing nut and slide the slot marking slide so that the keyframe notch corresponds with the keyframe mark you made on the keybed. (See Ill. 43)
 - Tighten the wing nut to hold this measurement.
 - Move the slot marking jig to the bottom side of the piano at the treble end.
 - With a pencil, mark the keybed on the notches that define the back side and the front of the slot.
 - Now do this measurement for the bass location as it may not be the same as the treble.
- If the slot locating jig is not available use the following procedure.
 - Measure from the keyframe line on the keybed (treble side) to the front edge of the keybed and transfer this measurement to the bottom side on the keybed.
 - Do the same measurement at the bass end of the keybed.
 - Using a drill guide, drill a 1/8" (3mm) hole at the keyframe cut line to verify this is the correct location. Do this at the bass and treble ends.
 - Look inside the piano to see if the hole is on the keyframe cut line. If not, then correct the line on the bottom side of the keybed.
 - Now measure from the keyframe line 11/16" (18mm) to locate the front solenoid slot line. (See Ill. 41)
 - Measure 4-5/8" (117mm) from the front solenoid slot line back to locate the rear solenoid slot line. (See Ill. 42)

- Make these same measurements at the bass end and then connect these vertical lines together creating the sides of the solenoid slot. (See Ill. 45 and 46)
- Locate the end of slot.
 - From the 1/8" (3mm) locating hole inside the piano, measure to the end of keyframe line and transfer this measurement to the bottom of the keybed. Do this for bass and treble ends.
 - Now add 1/2" (13mm) to the end of slot locations for additional room for key solenoids. (See Ill. 47)
 - Connect the end of slot lines and you are ready to cut the slot.

Note: If you need to drop more solenoids repeat step 3-A to define the top and bottom notes for the PianoDisc system and correct the scale stick.

- Make sure these marks are accurate as you will use these marks to define the front to back and end dimensions for the slot you will cut in the keybed.

8. Prepare to cut the solenoid slot.

NOTE: At this point it is best to plug the old shift lever hole if the forward key solenoid slot line goes thru it. It would be difficult to fill this later after cutting the slot.

NOTE: If the rear shift lever mounting block is 3/4" (19mm) from the forward slot line then you can skip this step as the shift lever and lyre log will not need to move. You will find that most pianos under 7' (213cm) will need the shift lever and lyre log moved forward.

- **Plug the old shift lever hole in the keybed.**
 - Cut a plug for the old shift lever hole from the material that will be cut out from the keybed to make the solenoid slot.
 - Cut the plug oversize and then fit it to the hole.
 - When done there should be a good snug fit.
 - Use epoxy or wood glue to secure the plug into place.
 - Use wax paper and a board to make the plug come out flat with the rest of the keybed.

9. Cut the solenoid slot

NOTE: NEVER USE A "SAWS ALL" OR JIG SAW FOR CUTTING THE SLOT. Only use a circular saw or router for a straight cut and the jig saw to finish the ends. A saws all or jig saw will not produce a straight (90 degree wall) cut. It is also recommended to use a straight edge or guide for a straight cut.

A. For pianos with the keybed attached.

- **Drill the corners.**
 - Measure the thickness of the keybed.
 - Put a 3/8" (10mm) drill bit in an electric drill.
 - Set up a masking tape flag on the drill bit at the thickness of the keybed. This precaution will keep the drill bit from bursting out the other side causing splintering on the top side of the keybed.
 - Drill through the keybed making sure to keep the drill as close to perfectly vertical as possible.
 - Drill one corner at each end of the slot for the jig saw blade access. (See Ill.49)



Illustration 49 - Drilling corners

- Wedge the damper tray.
 - Wedge up the damper tray away from the saw blade.
- NOTE: ALWAYS CUT THE ENDS OF SLOT FIRST. If the end cuts are done last, the saw blade may bind and the saw will come at you very quickly.**
- **Cut ends of the solenoid slot.**
 - Use an electric jig saw. (See Ill. 50)
 - Set the depth of the saw blade so that it will cut through the keybed yet will not reach the wedged up damper action.
 - If there is not a height adjustment for the jig saw, you can grind off the blade for clearance.
 - **Cut the sides of the solenoid slot.**
- NOTE: It is best to use a guide for the circular for a straight and clean cut.**
- Use a circular saw. (See Ill. 51 and 52)
 - Set the depth of the saw blade so that it will cut through the keybed yet will not reach the wedged up damper action.
 - Saw both sides of the solenoid cut.
 - Remove the remaining material from the cut.
- **Finish the cuts and clean up corners.**
 - Use an electric jig saw.
 - Finish the circular saw cuts with the jig saw.
 - From both directions cut into the rounded corner so that the corner is square rather than round.
 - **Smooth the cuts in the slot.**
 - Use a double cut file to clean up any rough spots.
 - Sand with 100 grit sandpaper to remove any splinters.
 - Sand with 220 grit sandpaper to finish.

B. For pianos with the keybed not attached.

- Drill the access holes
 - Put a 3/8" (10mm) drill bit in an electric drill.
 - Set up a masking tape flag on the drill bit at the thickness of the keybed. This precaution will keep the drill bit from bursting out the other side causing splintering on the top side of the keybed.
 - Drill one hole at each end of the slot for the jig saw blade access.
 - Drill through the keybed making sure to keep the drill as close to perfectly vertical as possible. (See Ill. 49)
- **Cut ends of the solenoid slot.**



Illustration 50 - Cut ends of slot

- Use an electric jig saw.
- Saw both ends from the holes in the corners.
- **Cut the front side of the solenoid slot.**



Illustration 51 - Cutting front of slot



Illustration 52 - Front and back cuts for slot

- Use a circular saw. (See Ill. 51)
- Use a guide so the saw will cut straight.
- **Cut the back side of the solenoid slot.**
 - Use a circular saw. (see Ill. 52)
 - Use a guide so the saw will cut straight.
- **Finish cutting slot and clean up corners.**



Illustration 53 - Finish from circular saw cuts



Illustration 54 - Keybed with slot cut

- From the circular saw cuts, use a jig saw and cut to the corner of the solenoid slot. (See Ill. 53)
- Remove the remaining material from the cut.
- Make the corners square and straight.
- **Smooth the cuts in the slot.**
 - Use a double cut file to clean up any rough spots.
 - Sand with 100 grit sandpaper to remove any splinters.
 - Sand with 220 grit sandpaper to finish.

10. Reinforce the keybed.

A. On the old system.

- If the keybed was the traditional tongue and groove as in a Steinway, it was necessary to reinforce the keybed.
- This was because the slot removed surrounding support to the plank in question and the old Rail Cover had no structural strength.

B. On the new Low Profile system.

- It is no longer necessary to reinforce the keybed.
- The tray, on which the system is mounted, is heavy gauge steel shaped like structural channel.
- Because the tray is so sturdy, when attached to the keybed, the tray reinforces the keybed, tongue and groove or otherwise.

11. Cut leg tops to clear the solenoid slot.

A. Get the appropriate legs for the bass and treble sides of the keybed.

- Usually the manufacturer designates the location of the legs.

- As part of the tear down procedure you marked the tops of the legs indicating their position in the piano.
- If the manufacturer did not designate the location of the legs it means when the piano was made that the legs would work in any of the three locations.
- After PianoDisc installation, this is no longer true. Once you modify legs for PianoDisc, all three legs will become unique and thus will only work when attached in their designated locations.

B. Attach legs to the keyed.



Illustration 55 - Legs attached to keyed off piano

- Attach the bass and treble legs to the keyed. (See Ill. 55)

C. Mark legs for the slot location.



Illustration 56 - Trace slot on leg top

- Trace the slot location on the top of the legs in the bass and treble locations.



Illustration 57 - Mark cut on top of leg

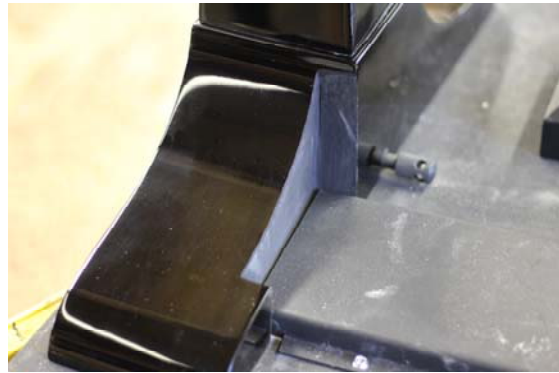

Illustration 58 – Leg cut complete

- If the leg is attached to the keybed with a wedged interlock, you may need to add an additional 3/8" (10mm) so that the leg can be installed or removed.

D. Mark the legs on the finished side so you can see the lines.

NOTE: In most cases you will be notching an "L" at the end of the legs and not the "U" shape as in Ill. 58. It as depends of the location of the leg.

- Tape the area of the leg top in which the cut will occur.
- From the marks on the keybed side of the leg top, use a square to transfer them to the finished side of the leg top.
- When done you should have the notch in the leg marked just like you measured it on the keybed side of the leg.
- In most cases the notch will go to the end of the leg.

E. Cut legs.

- Secure the leg so it cannot move during cutting.
- Use an electric jig saw to cut the legs.
 - Some legs it may be necessary to use a pull saw to make the cut because of the thickness of the legs.
- File and sand the area of the leg cut.
- Stain or paint the exposed area of the leg top to match the appearance of the bottom of the piano.

12. Assemble the tray, solenoid rails and guide solenoids.

NOTE: To make access for the end plates, please go to the Addendum 3 on page 80 and view the procedure for rail clearance at this time before cutting the solenoid rails.

A. Calculate the length of the solenoid rails.



Illustration 59 - Mark rail from end



Illustration 60 - Key scale stick on rail

- Measure from the bass end of the rail $\frac{3}{4}$ " (19mm) and mark. This is where the bottom note in the system will occur on the rail. This line represents the center of the plunger stem.
- Lay the key end scale stick on the rail.
- Mark on the rail where the top note in the system will fall from the key end scale stick.
- Measure out from the top note mark $\frac{3}{4}$ " (19mm) and mark. This is the end of the rail mark.
- The rail should be about 6mm shorter than the slot you defined. (See Ill. 61) Measure the length of the slot and the rail length just designed and confirm. If the numbers do not work, look for your error. Do not continue until any discrepancies are resolved.

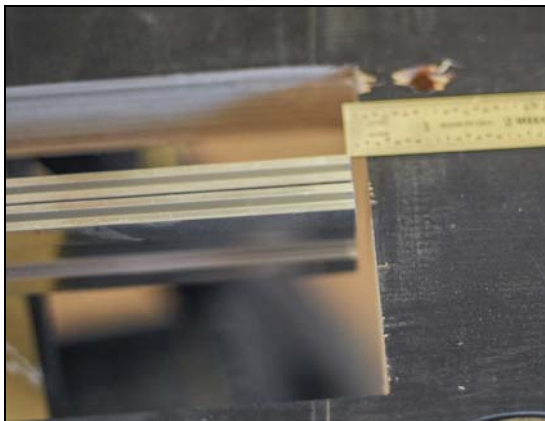

Illustration 61 - Rail $\frac{1}{4}$ " (6mm) shorter than slot



Illustration 62 - Marking cut line on rails

- Mark the second solenoid rail to the same length. (See Ill. 62)

NOTE: Before cutting the rails please go to the Addendum 3 on page 79 for instruction for the end plate clearance.

B. Cut the rails.



Illustration 63 - Cutting rails

- Use a square and a scribe to mark a square cut line on both rails as designed.
- Use a band saw to cut the rails as designed.

C. Design the length of the tray.

- The tray should be $\frac{1}{4}$ " (6mm) longer than the solenoid rails and cover the slot.
- Mark the length of the tray.

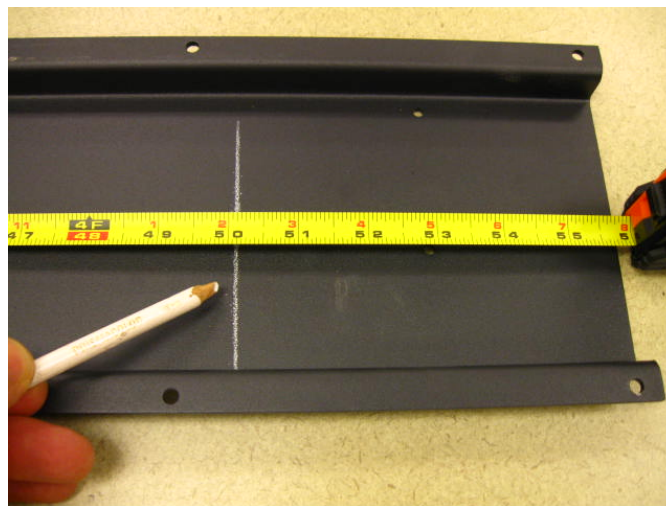

Illustration 64 – Marking the cut line of tray

- Measure from one end of the tray the total length needed and mark tray for cut. The length of the tray should just cover the solenoid slot.
- Use a square and a scribe to scratch a square cut line.

D. Cut the tray.

- Use a hack saw, a powered hacksaw, or a metal cutting band saw to cut the tray to length.
- File off the end of the rail and color with a permanent black marker.

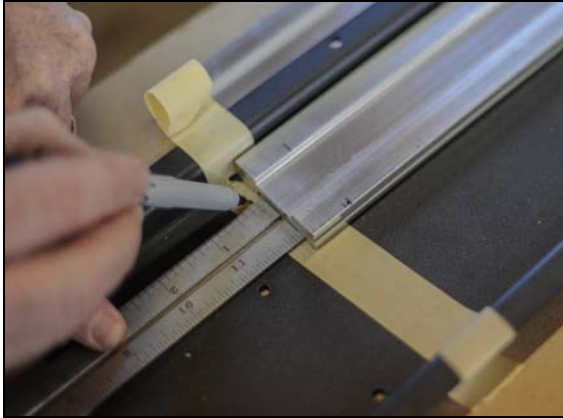

Illustration 65 - Measure end of tray from rail



Illustration 66 - Black end of mounting tray

E. Mount the solenoid rails on the tray.



Illustration 67 - Mount solenoid rail on tray

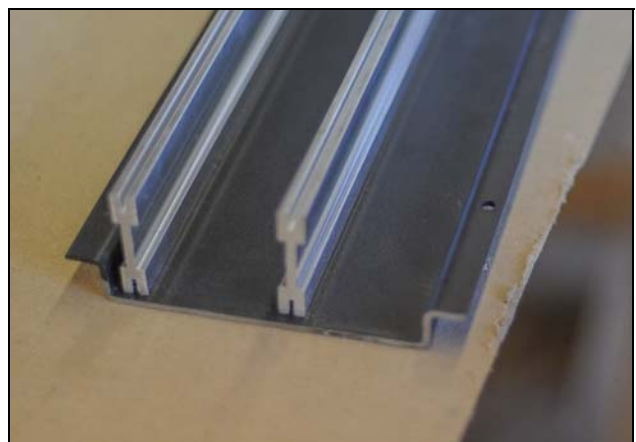

Illustration 68 - Tray with solenoid rails

- Position both solenoid rails in from each end by 1/8" (3mm).
- Use 6 hex screws through the mounting holes in the tray to attach each rail.
- Mount both rails and if correct, mount all screws into the rails.

F. Mounting end key solenoid assemblies.

NOTE: Temporally place the solenoid rest felt in the tray for the support of the plunger as you must drill the sostenuto hole before securing the felt to the tray.

- Mount the bass solenoid so that the “center” of the lowest note in the system is $\frac{3}{4}$ ” (19mm) in from the end of the rail.
- Place the end solenoids on the rails. (See Ill. 69)
- Using the scale stick, align and attach the key solenoid assemblies.



Illustration 69 – Installing bass solenoid assembly

- Locate the tray assembly left to right so that the solenoid plungers are as close to centered under the end keys as possible.
- Verify the alignment is correct looking from the top thru the strings.
- Place 2 mounting screws into each end of the tray assembly.

13. Installing the Trapwork.

A. Locate the shift lever in relation to the cover tray.

- Locate the 3” (75mm) line drawn on the bottom of the keybed in step 2-H. If the line is on the top of the keybed then transfer to the bottom.
- Hold the shift lever assembly, with the mounting blocks attached, $\frac{1}{16}$ ” (1.5mm) from the cover tray flange. (at the 3” (75mm) line)
- If the cover tray is not on the keybed, place the rear lyre block $\frac{3}{4}$ ” (19mm) from the solenoid slot cut.
- Mark the center location for the shift lever hole on the 3” (75mm) line.
- Figure from the 3” (75mm) mark the amount the shift lever was moved from the original location.
- This will be the same distance to move the lyre log.

B. Drilling Shift lever hole

- Prepare for drilling.
 - Mark the center of the hole with a center punch.

- Cover the spot where the drill will emerge on the bottom of the keybed with a piece of soft wood.
 - Clamp the piece of wood into place so the keybed cannot splinter.
- Drill the new shift lever hole.
 - Use a 1-1/2" (38mm) Forstner drill bit or a hole saw.
 - Drill through the keybed making sure to drill vertically until you are into the protective piece of wood. A drill guide is recommended.
 - Remove the clamp and protective piece of wood.

C. Mount the lyre log on the keybed

- Place the log on the keybed at the new location.
 - The new log location is determined by the amount the shift lever needs to move.
 - Mark the hole locations and pilot the screw holes.
 - Flag the drill bit with tape slightly less than thickness of the keybed.
 - Drill the pilot holes.
 - Mount the keybed to the new location.

D. Mount the tray assembly on the keybed.

- **Attach the guide solenoids to the rails.**
 - Place only the first and last solenoid assemblies of each section to properly align the solenoid tray to the keybed. The screws for mounting the tray are #8x1" (25mm) supplied in the kit.
- **Position the tray left to right so that the solenoids align with the keys.**

On the bench

- Place the end of section keys on the keyframe with the top action attached.
- Set the action on the keybed using the marks you made to locate the action.
- Block up the ends of the keybed with saw horses so that you can position the tray assembly under the keys.
- Using a cart or table to support tray assembly, locate the tray assembly front to back under the solenoid slot such that the inside steel surface of the tray is aligned with the front edge of the solenoid slot.
- Elevate the tray assembly so the tray flange is against the keybed.
- Locate the tray assembly left to right so that the solenoids are as close to centered under the end keys as possible. The back row of solenoids should be 3/8" (6mm) on to the keys.
- Install 2 mounting screws into each end of the tray assembly.

In the piano

- Remove the top action from the keyframe.
- Place only the end of section keys on the keyframe.
- Move the keyframe into the action cavity and position properly with end blocks.
- Locate the tray assembly front to back over the solenoid slot such that the inside steel surface of the tray is aligned with the front edge of the solenoid slot.
- Locate the tray assembly up and down so that the solenoids are as close to centered under the keys as possible. The back row of solenoids should be 3/8" (6mm) on to the keys.
- You can see this from the top thru the strings.
- Install 2 mounting screws into each end of the tray assembly.

E. Mount the keybed to the piano if not attached.

- Place the keybed on the piano with the tray assembly attached.
- Secure with 1 screw at each end.
- Place the keyframe into the piano with end blocks in place.

F. Mounting the shift lever

Note: Ideally this is the best way to locate the shift lever on the keybed. Because of the leverage in the shift lever, even a small error is potentially a big problem. It is impossible to know where the shift lever should be positioned left to right, or in this case, up and down, unless the action is held firmly against the bass stop block by the shift spring.

- Center the domed nut on the lyre rod.
- Center the shift lever front to back in the hole.
- Make sure the pad is aligned correctly with the pedal rod.
- Slide the shift lever up until it engages the keyframe.
- Secure shift lever with the original screws.
- Check to make sure that there is no slack between the shift lever and the keyframe.
 - Correct now if you have this problem.

G. Calculating and making sustain lever

Note on using the right equipment: When drilling the trapwork it is best to use a drill press to drill all the holes accurately at 90 degrees.

NOTE: The following trapwork parts are supplied in the kit for the sustain and sostenuto trapwork.

1. 2 pieces of maple wood – 1”(25mm)x 1”(25mm) x 24” (61cm).
 2. 2 metal pivot brackets.
 3. 8 - #8 x 1” black hexhead mounting screws.
- Place the lyre on the piano.
 - Measure from the sustain pedal rod to an approximate point where the old pitman arm made contact with the damper tray. Average out this distance according to the angle which be will needed on the sustain lever. Please refer to the following illustrations.

H. Installing the pedal solenoid

NOTE: It may be necessary to place a block of wood on the beam as a spacer for better alignment. (See III. below)

- **Locating and installing the pedal solenoid.**
 - Glue felt, supplied with solenoid, to the side of the pedal solenoid to cushion between the beam and solenoid.
 - Center the sustain lever over the solenoid rail cover outline.
 - Place the pedal solenoid on the beam aligning with the 6” location established
 - in the previous step.
 - Attach the pedal solenoid with black screws, #6x1” (25mm) supplied in the kit.

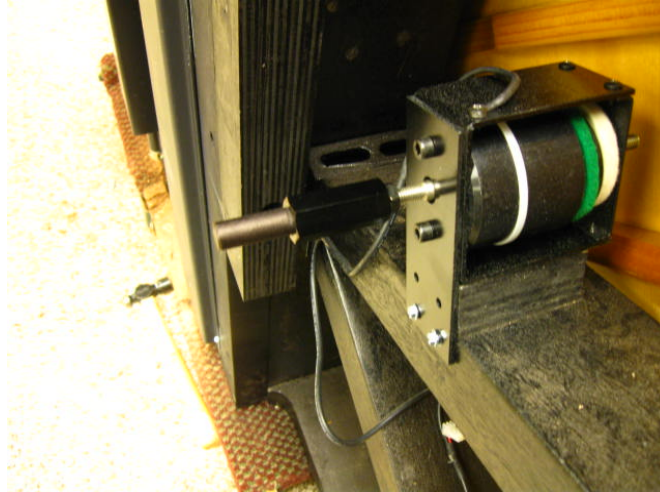

Illustration 70 – Mounting pedal solenoid

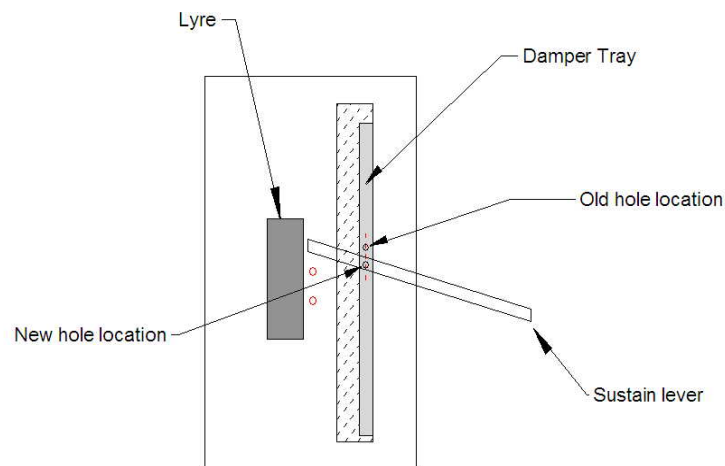

Illustration 71 – Locating sustain lever

- The distance from the sustain pedal rod to the approximate new hole location on the damper tray should be 60% of the total measurement from the sustain pedal rod to the lever pivot. From pivot point to the sustain pedal solenoid location will be an additional 6" (150mm) back on most pianos. Please refer to the following illustration.

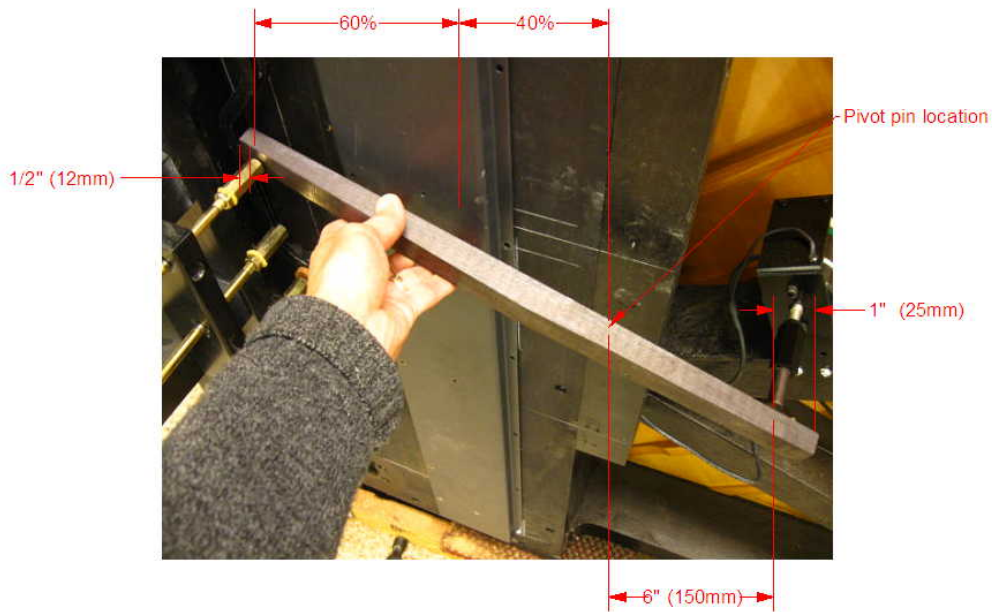

Illustration 72 - sustain lever dimensions

- Hold the lever in position as shown above to determine how long the lever will be, where you must drill for the pitman, and pivot pin. Mark these locations and proceed with making the sustain lever.
- Where the sustain lever makes contact with the pedal solenoid, mark $\frac{1}{2}$ " (13 mm) past the $\frac{3}{4}$ " (19mm) nut on the pedal solenoid contact area and place a mark to cut off excess lever.
- Once the lever is cut to size paint it to match the original color of the original levers.



Illustration 73 – finished and unfinished sustain lever



Illustration 74 – Finished installed sustain lever

- **Installing the stop block and stop screw.**

This is a method of adjustment that all Mason & Hamlin Pianos are now equipped with. The idea is to make the stop screw easy to access. The stop pad is used for the stop screw. The spring leather will prevent the spring from making any kind of undesirable noise while the felt with keep the spring aligned.

- Mark the location for the glide bolt.
 - Locate the glides, stop blocks, springs, felt, leather and screws in the kit.
 - Place the glide bolt 1" (25mm) behind the lyre rod contact point.
 - Drill a 5/16" (8mm) hole and tap with a 3/8" (9.5mm)-16 tap.
 - Install the glide bolt into the lever.
 - Locate the position for the stop block under the glide and glue in place on the keybed.
 - Make final adjustments later.

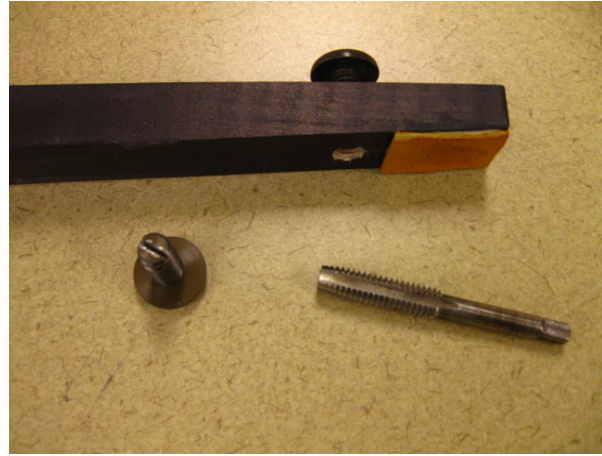
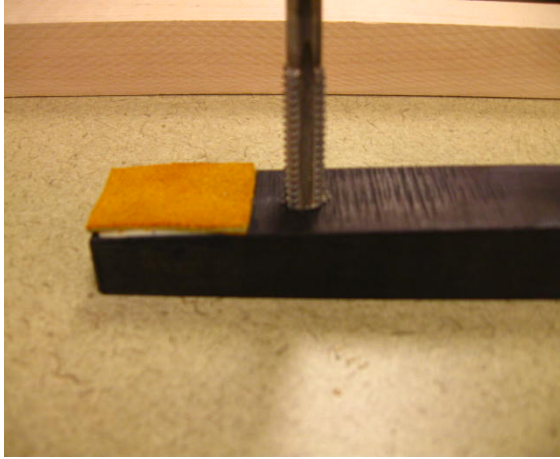

Illustration 75 - Stop glide and tap

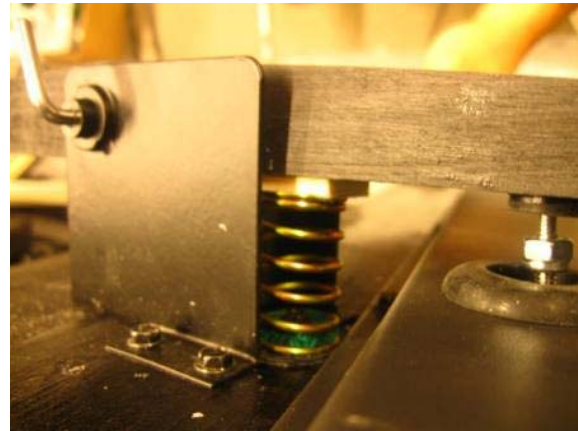
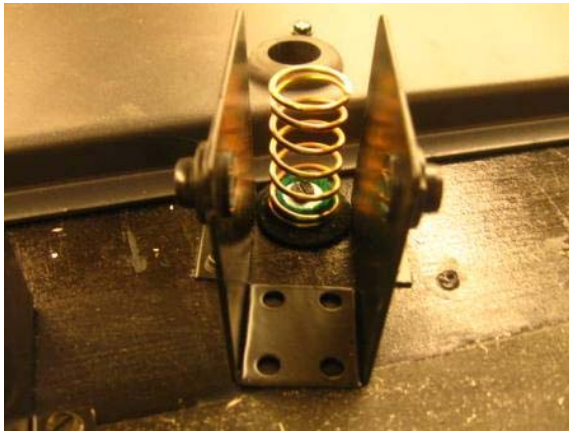

Illustration 76 – Sustain lever spring

- Mark the location for the sustain return spring. Usually the ideal location is 1"-2" from the pivot pin. (see Ill. 76)
- Install the leather/felt at this location on the keybed with the screw and washer provided.
 - Note how the screw and washer, when tightened, make a snug fit for the spring.
- Place the spring on the leather and install lever locating the spring contact point on the lever.
- Remove the lever and glue on the ¾" (19mm x 1" (25mm) white felt at the spring location. (See Ill. 76)
 - Use a contact cement for the white felt.

Pianos with no support beam

In this case, it is necessary to install a beam of wood to mount the sustain solenoid and possibly a speaker. Use a 4" (10cm) x 6" (15cm) piece of wood attached by metal "L" brackets on the belly rail. At the rear end of the piano use glue and attach to the leg base console with two screws. (See Illustration 71)

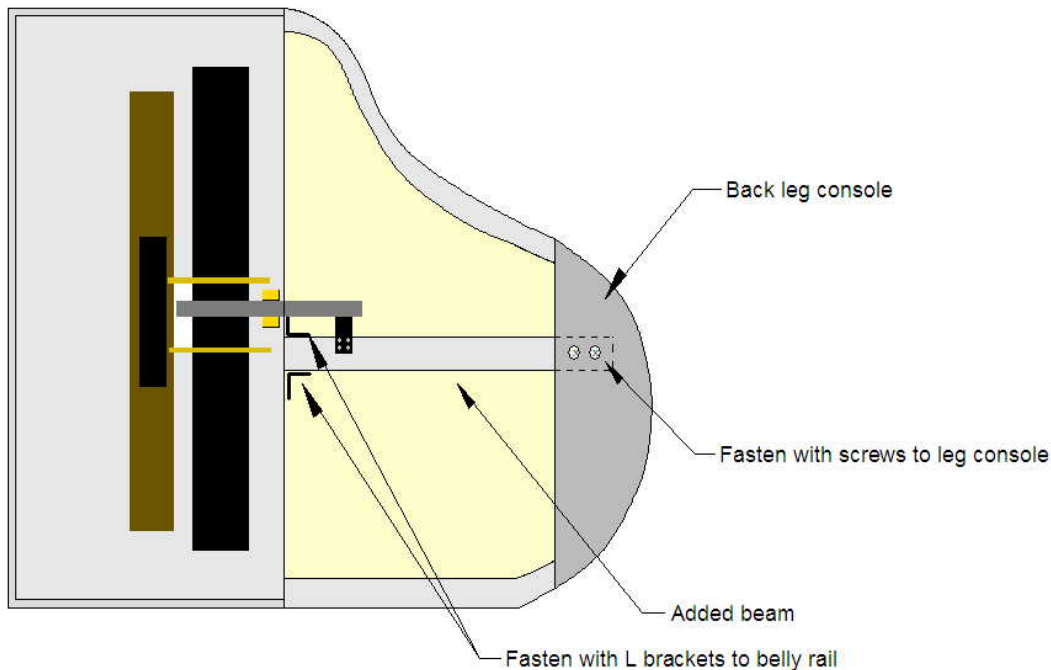

Illustration 77 - Pianos without support beams

I. Finish preparing of Sustain lever

- **Installing the rubber grommet in the damper tray.**
 - With the sustain lever back in place look down the sustain lever and at the damper tray, mark the location to drill a $\frac{23}{64}$ " (9 mm) hole for a rubber grommet.
 - Locate the rubber grommet, supplied in the kit, and glue in the grommet with contact cement or super glue.
 - Center the sustain pedal rod on the lyre and center the $\frac{3}{4}$ inch (19mm) nut on the pedal solenoid. This is important for adjustability later.
- **Place the appropriate felt and spacer (if necessary) between the sustain lever & pedal rod.**
 - The front part of the lever should have either leather or felt placed between the lyre pedal rod and the lever.
- **Prepare the threaded rod.**
 - Place a self locking nut on the $\frac{8}{32}$ " (6.5 mm) rod with $\frac{1}{2}$ " (13 mm) of rod exposed.
 - Glue a flat washer onto the nut for more support area. Use super glue or contact cement.
 - Measuring and cutting the threaded rod. (See Ill. 78)
 - Place the threaded rod (nut end) into the grommet on the damper tray.
 - Now pull the dampers down to the strings and the damper tray up to the damper leavers.
 - Now, mark the threaded rod, to be cut off flush with the bottom of the sustain lever.
 - At the same time, mark the location where threaded rod hole will be drilled on the sustain lever.
 - Cut the threaded rod to the make flush with the bottom of damper leaver.
 - File off the threads and install a self locking nut at the distance of $\frac{3}{4}$ " (19mm) and glue a flat washer to the nut with contact cement.

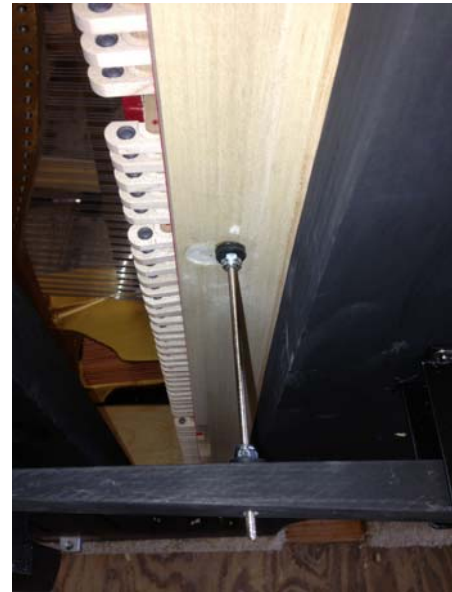
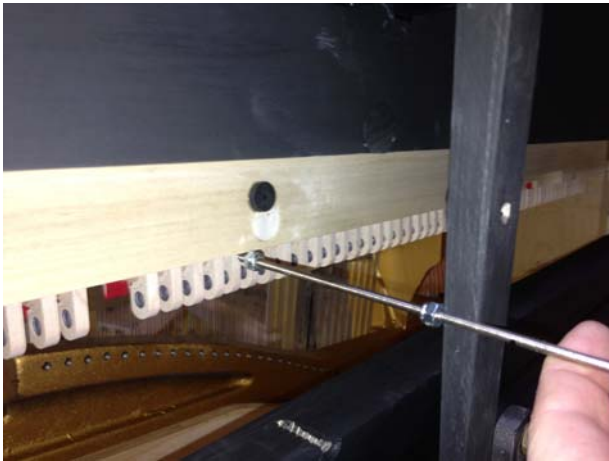

Illustration 78 – Finding length and placement of the sustain pitman rod

- **Drilling lever for threaded rod hole.**
 - Remove the threaded rod and sustain lever.
 - With a ¼" (6mm) drill bit, drill thru the sustain lever where the pitman will be located.
 - Now with a 23/64" (9mm) drill bit, drill **halfway through** the ¼" (6mm) hole you just drilled through the lever.
 - Glue grommet in place with C & A (super) glue.

- **locating and installing sustain pedal return spring.**
 - On most pianos, the sustain pedal feels lighter than the original trapwork. To replace the same feel to the pedal, a spring can be added to the sustain pedal as follows:
 - Remove the bottom of the lyre and the sustain pedal.
 - Drill a 1" (25 mm) hole ½" (13 mm) deep into the lyre.
 - Felt the circumference to the hole with thin felt.
 - Place the spring in the hole and reassemble the lyre.

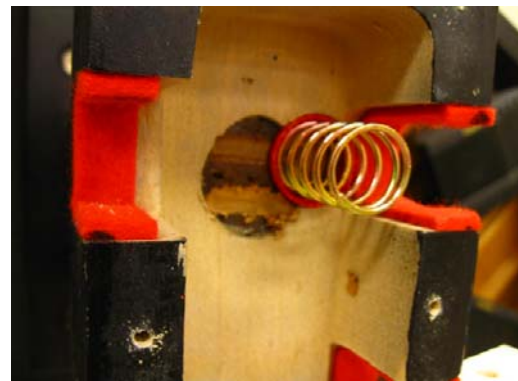
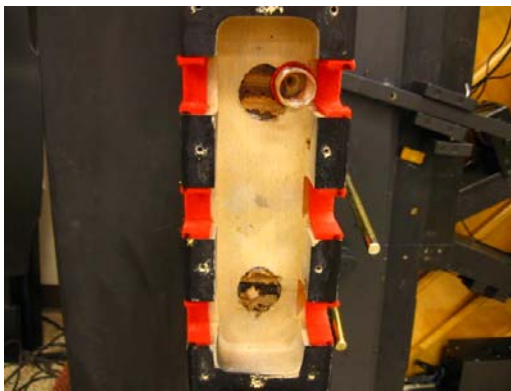

Illustration 79 – Installation of sustain pedal spring

J. Making and Installing the sostenuto lever

Please Note: PianoDisc requires a working sostenuto on all pianos if so equipped.

NOTE: For American Steinway pianos with the sostenuto on the action, please refer the Addendum at the end of this manual.

NOTE: The following trapwork parts are supplied in the kit for the sustain and sostenuto trapwork.

1. 2 pieces of maple wood – 1”(25mm)x 1”(25mm) x 24” (61cm).
2. 2 metal pivot brackets.
3. 8 - #8 x 1” black hexhead mounting screws.

Please refer to the first steps provided in trap work installation that refers as to how the sostenuto push vs. pull configurations are identified.

Please note: If the sostenuto is a push (although it is possible to use a 2 lever system) we recommend that you use a one piece lever. We will be describing in the steps that follow these illustrations that show how push and pull levers are based on the location of the fulcrum pivot location.

- Check the sostenuto rod installed in the piano to decide if it is a push type or pull type sostenuto.
Note: With pull type the clip is on the front side. With a push type the clip is on the rear side of the sostenuto rod. Please refer to the following illustration.

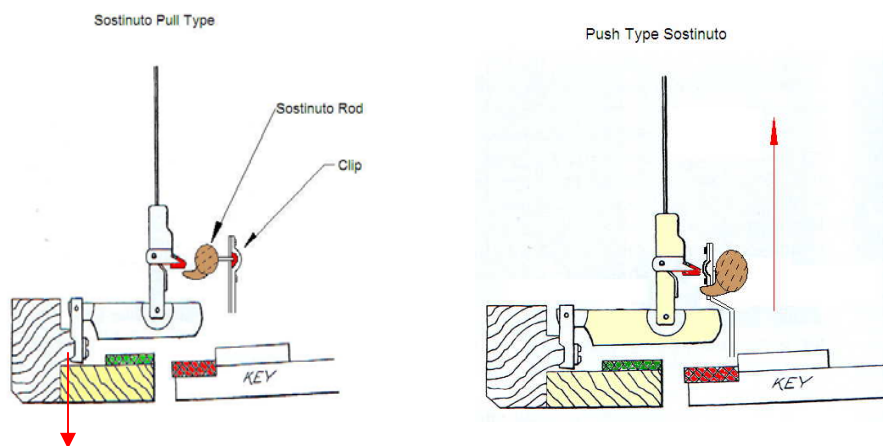

Illustration 80 - Sostenuto push and pull example

The following will provide a description of how you can locate the fulcrum / pivot location of any lever to convert the lever from a push to a pull type configuration.

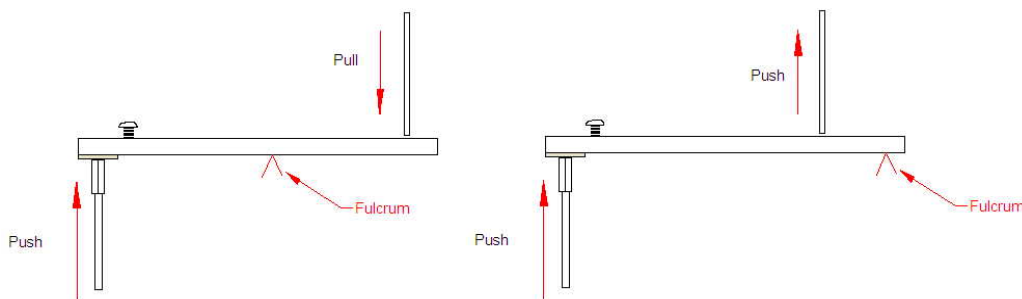

Illustration 81 -Single lever push/pull

Push or pull type sostenuto

NOTE: This procedure below of locating the hole location thru the solenoid tray is for either push or pull sostenuto system.

- Mount the tray to the piano at the predetermined location with screws slightly loose to slip the wedge under the tray.
- Place a wedge of wood at the sostenuto mark that was marked previously.
- Secure the wedge of wood to the keybed.
- This wedge will help locate where the threaded rod is located on the tray and sostenuto lever. Please refer to the following illustration.

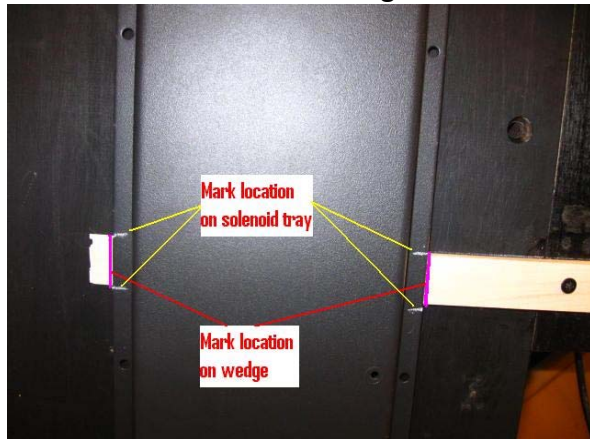

Illustration 82 – Lever location to tray

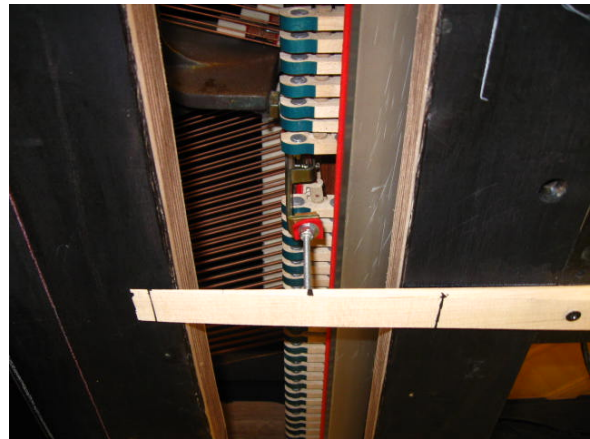

Illustration 83 - Pitman location to wedge

- Mark the location of the tray flange on the wedge for a reference.

NOTE: At this time mount the sustenuto lever back on the piano and locate the pitman rod on the tray. Make sure to use a square to locate hole correctly.

- Remove the tray and mark the 90 degree location of the threaded rod to the wedge. (see Ill. 84)
- Now remove the wedge and place of the tray.
- Mark the pitman location on the tray. (See below)



Illustration 84 – Sostenuto hole location



Illustration 85 – Hole punch and Carbide drill for tray hole



NOTE: There are 2 optional tools that will cut the hole in the tray cover. (See III. 85) On the left the Greenlee hole punch and on the right the Carbide drill.

For the Greenlee hole punch

- Drill a 23/64" (10mm) hole thru the tray at the location marked. Do this on both the sostenuto and sustain locations at this time.
 - Place the hex head bolt on the out side of the tray and the cutter on the inside.
 - Use either an impact wrench with a six point socket or a ratchet and socket

NOTE: For the Greenlee hole punch, it is important to lubricate the threads of the hole punch occasionally for long life.

- The Greenlee hole punch, #35178, can be purchased from many companies on line. (See III. 85)
- The Carbide drill can be purchased from Blair Equipment Company, part # - 14732. (See III. 85)

Making the push type Sostenuto Trapwork

NOTE: For American Steinway pianos please go to the Addendum 1 on page 76 at the end of this manual for additional information.

- Mount the rail cover back on the keybed.
- You will need to make a pattern of the sostenuto lever. (See III. 86)
- Use paper or a transparent material to create the pattern. It will take some observation and calculation to determine the shape needed.
- Place the pattern as shown on the keybed and draw the shape needed on the paper.
- Once you have finished the pattern, transfer to a piece of plywood. The plywood is not supplied in the kit and we recommend that you use a good quality plywood such as Baltic birch. Use a thickness of 3/4"(19mm)-1"(25mm) plywood.
- Cut out the plywood pattern and sand to create a look more symmetrical and appealing to the overall visual appearance.

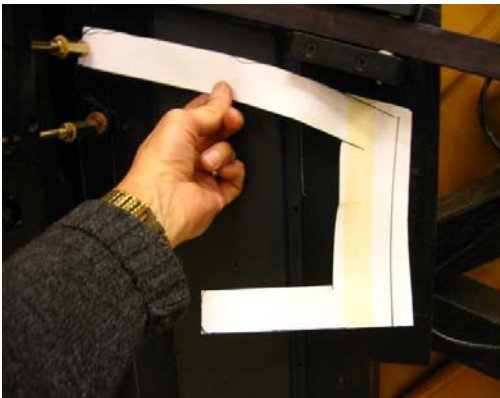

Illustration 86 - Sostenuto Pattern



Illustration 87 - Sostenuto Pattern on plywood

- Since this lever shape is made of plywood, you will need to place a hardwood support for the pivot pins. In this case we used maple which is supplied in the kit.
- Design the plywood lever to attach a hardwood support area. (See Ill. 88 and 89)
- Another option is to just join the plywood and hardwood pieces with a simple butt joint secured with two wood screws. (See Ill. 88)
 - Make sure the glued surface is rough for a good glue joint. Use 60 or 80 grit sandpaper to rough up wood surface.
 - Use a 2" (50mm) wood screw the two pieces together.
 - Drill an access hole thru the plywood
 - Drill a pilot hole into the hardwood. Be careful not to make the hole too small.
 - Attach the two pieces together with wood glue.
- Glue and clamp the hardwood support to the plywood lever. This is an important step as this support is necessary.

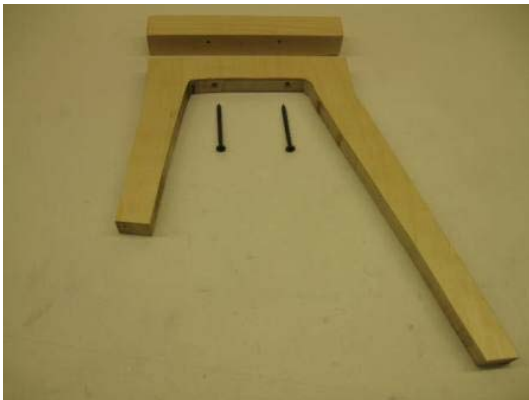

Illustration 88 – Optional butt joint connection



Illustration 89 - Lever with hardwood addition

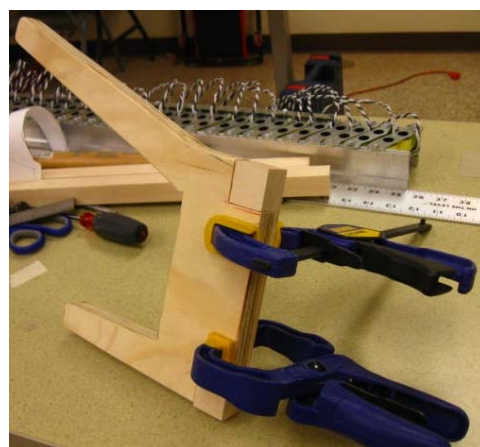

Illustration 90 - Sostenuto lever assembled



Illustration 91 - Sostenuto lever ready for pivot pins and glide stop

- Once the lever is cut and assembled it is ready for the final additions.
 - Round off all corners and sand all surfaces for painting.
 - Paint the lever black or other color that will match the color of the original trapwork.
 - Locate the metal pivot bracket and pins in the kit.



Illustration 92 – Trapwork bracket cut in half



Illustration 93 – Cut trapwork pin in half

- The single bracket will need to be cut in halve to create two brackets. (See Ill. 88)
- The single pin in Illustration 89 will also need to be cut in half to create 2 – 1" (25mm) pins to be attached to each side of the trapwork. Cut off the tag as it will not be used.
- Drill an 11/64" (4.36mm) hole ½" (13mm) deep into the hard wood at each end of the lever for the pivot pins.
- Glue each pin with epoxy for a good secure fit.

- Add the glide stop screw.
 - Place the glide bolt 1" (25mm) behind the lyre rod contact point.
 - Drill a 5/16" (8mm) hole and tap with a 3/8" (10mm)-16 tap.
 - Install the glide bolt into the lever.
 - Locate the position for the stop block and glue in place. (See Ill. Below)
 - Make final adjustments later.
- Another stop block is glued to the keybed towards the back of the lever for the return spring. (Please refer to the following illustration below)
- Locate a piece of leather in the kit and add to the location where the lever will rest on the lyre rod.
- A hole is drilled in the lever to accommodate the threaded rod. Note: when the threaded rod is attached to the lever there will be a felt washer, a metal washer and a lock nut on each side of the lever that will hold the threaded rod securely to the lever.

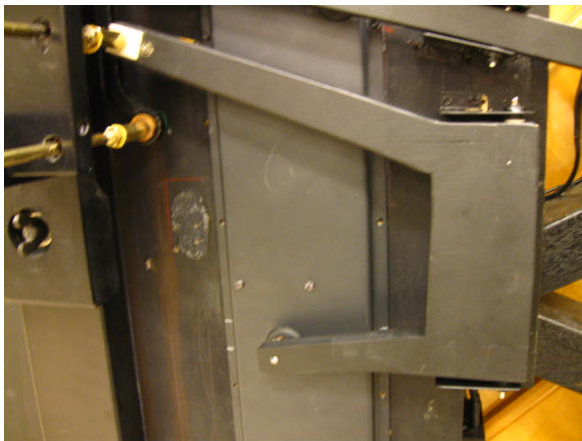

Illustration 94 - Sostenuto lever installed

Pull style sostenuto

The pull style sostenuto is a single lever system which will work on most pianos. PianoDisc has provided the lever and pivot bracket in the kit. The following instructions will aid you in assembling and installing this lever.

- Locate the hard wood lever and bracket in the kit.
- Measure the total length of the lever from the pedal rod to the contact point on the sostenuto rod.
- Drill the 5/32" (4mm) pivot hole half the distance of the lever. (See Ill. 95)
- Install the lever into the bracket with the pivot pin provided.
- Place the lever on the keybed aligning with the pedal rod and mark for the clearance of the shift pedal if necessary. (See Ill. 96)

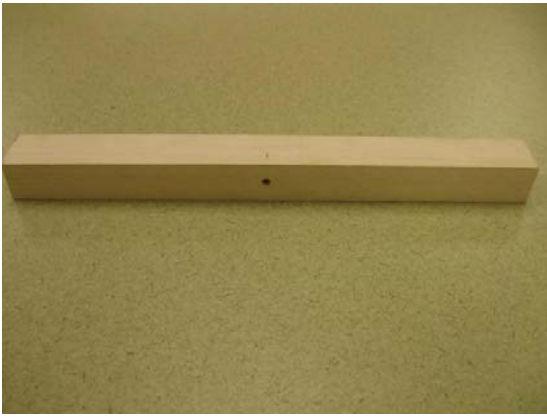

Illustration 95 - Sostenuto pull lever

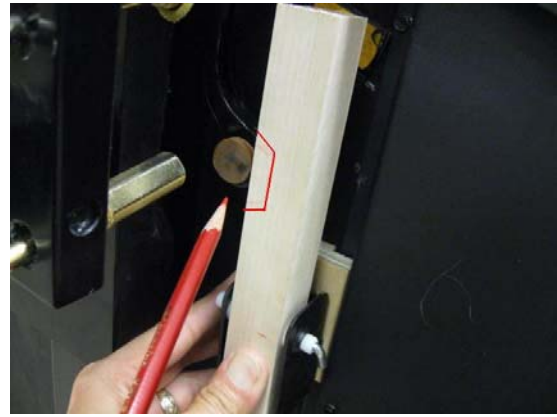

Illustration 96 - Sostenuto lever

- Now using the excess wood from the lever supplied, make a lap joint to extend to contact the pedal rod. (See Ill. 97)
- Make the cut on the two pieces of wood and attach the lap joint with wood glue and screws. (See Ill. 98)

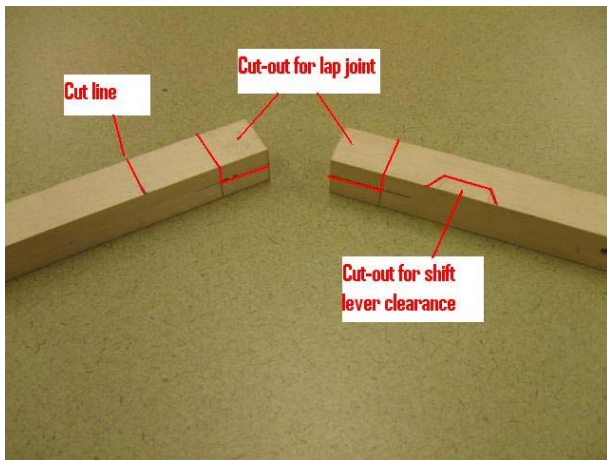

Illustration 97 - Sostenuto lever

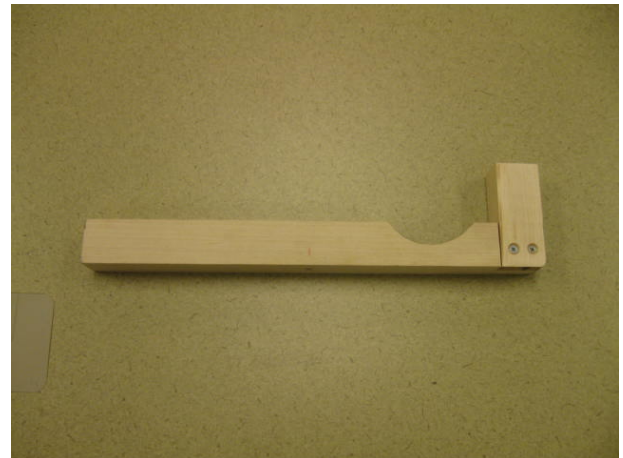

Illustration 98 - Sostenuto lever

- Place the lever back on the keyboard and measure for the distance to the sostenuto rod.
- Using the excess wood from the levers supplied, make the lap joint, glue and screw together. (See Ill. 100-102)

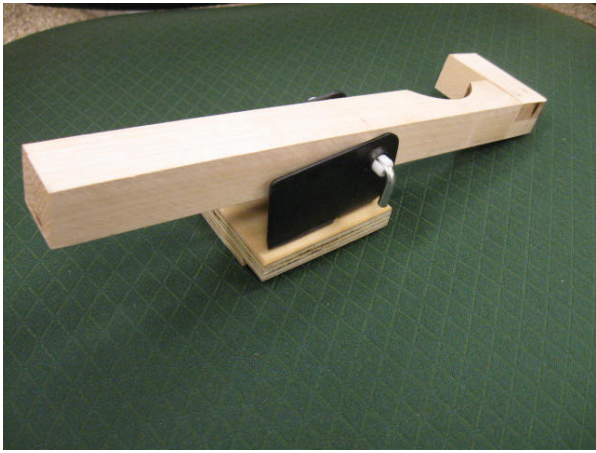

Illustration 99 - Sostenuto lever

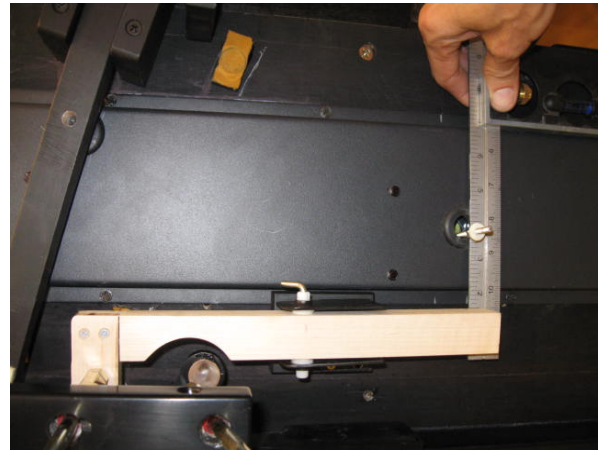

Illustration 100 - Sostenuto lever

- Sand the lever rounding off the sharp edges and paint to the desired finish.
- Glue on the leather for the pedal rod contact and felt for the stop screw. (see Ill. 103)
- Attach the lever to the piano. (See Ill. 104)

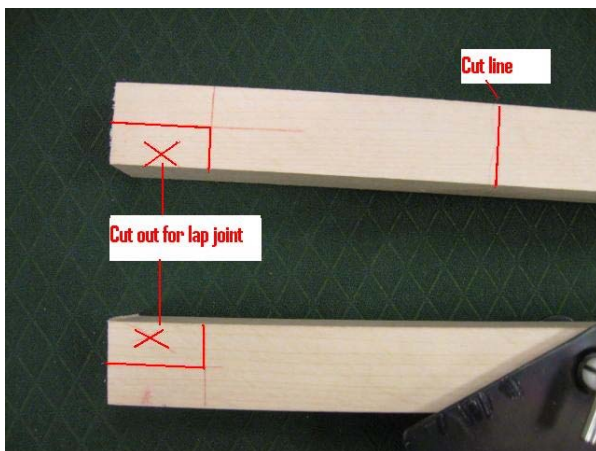

Illustration 101 - Sostenuto lever lap joint



Illustration 102 - Sostenuto lever assembled



Illustration 103 - Finished sostenuto lever



Illustration 104 - Lever Installed

- **Adding the adjustable glide bolt and return spring.**

- The adjustable glide bolt should be located just slightly behind the lyre rod towards the tray.
 - Mark the location for the glide bolt
 - Drill a 5/16" (8mm) hole and tap with a 3/8" (10mm)-16 tap. (see Ill. 106)
 - Install the glide bolt into the lever. (See Ill. 107)
- Locate the position for the stop block and glue in place.
- Make final adjustments later.

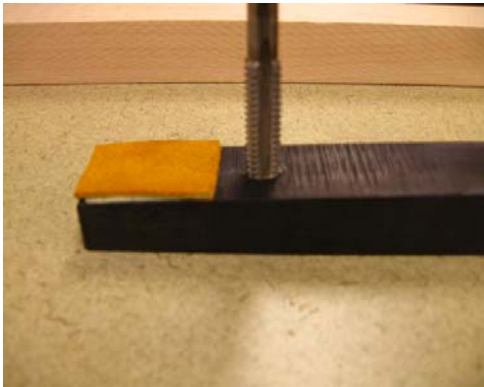

Illustration 106 - Taping for glide stop



Illustration 107 - Glide stop installed

- Locate the 2 - 1-1/8" (28.5mm) leather punchings and 2 - 11/16" (17.5mm) felt punchings, 2 mounting screws and 2 washers in the kit.
- Select the location for the spring, usually next to the stop screw at the lap joint location.
- Attach the felt/leather with the screw and washer provided. (See Ill. 108)
- Note how the screw and washer, when tightened, will make a snug fit for the spring.
- Locate the 2 - white felt, 3/4" (19mm) x 1" (25mm) in the trapwork baggie. This felt is place on the lever to cushion the spring. (See Ill. 108)

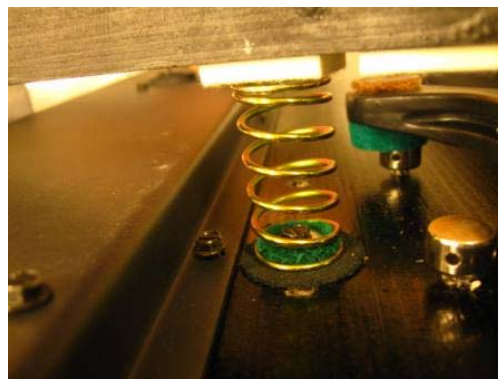

Illustration 108 – Return spring and mounting

Attaching the threaded rod to the sostenuto coupler

Before proceeding, it is important to determine exactly how the sostenuto linkage is connected on the particular piano you are working on. The sostenuto coupler varies a great deal from one piano to another. In examples A thru C, the rod connects in various ways. In example A, use a 5/8" x 2 1/2" (16 mm x 76 mm) wood dowel to make the connection. (See Ill. 109 to 111)

- Approximately half of the rod must be cut off.
- Using the correct size of die, thread 1" (25mm) of the rod.
- Then use the correct size of drill bit (interference fit) to drill the dowel.
- Use super glue on the rods during assembly for a permanent bond.

Example A

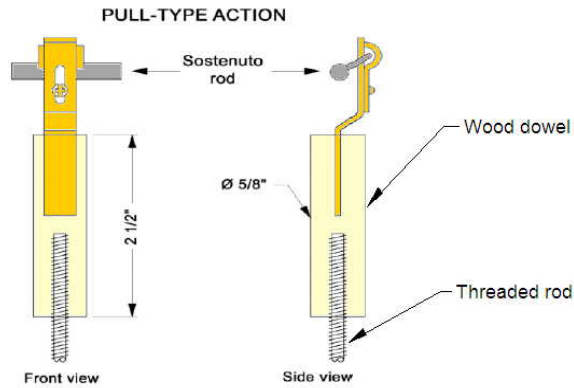

Illustration 109 – Sostenuto connect with super glue and wood dowel

Example B

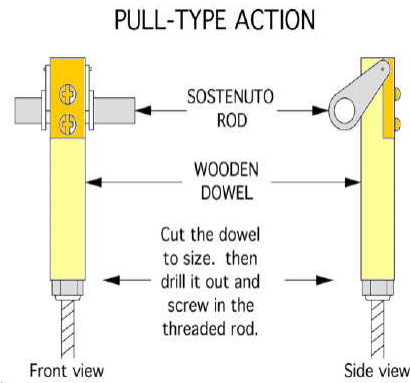
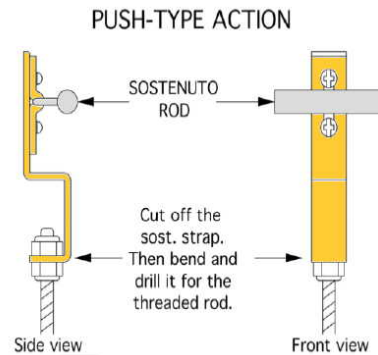

Illustration 110 – Sostenuto rod secured into dowel with super glue

Example C



14. Adjusting the key solenoid plungers

Keybeds that are not removable

This is a rough adjustment as the final adjust for keybed that are not removable will be done with the piano on its legs.

- A. The solenoid plungers will arrive pre-assembled.
 - You will need to adjust the solenoid plungers.
- B. Decide on the initial length of the solenoid plungers.
 - Measure the thickness of the keybed.
 - Measure the height of the back of the key above the keybed.
 - Add these two measurements and add 3/8" (10mm) for the amount of plunger in the tray.
 - This is the approximate length you will need for the solenoid plungers.
- C. Set adjusting jig to the calculated plunger length. (See Ill. 112)
 - Adjust all plungers to length.
 - Place the correct sample solenoid plunger into jig.
 - Adjust the bolt to the rubber plunger tip.
 - Adjust all solenoid plungers in the same manor.

Keybeds that are removable

With the keybed on the table and the solenoid tray attached in its final location, a fine adjustment is easy to accomplish at this time.

- A. Place the keys on the keyframe and attach the stack or top action.
 - Place action on the keybed with the end blocks and the correct side to side location.
 - Place the solenoid tray on the keybed with 8 mounting screws.
 - Place a key solenoid plunger in a solenoid and adjust the height.
 - This will be the sample for all the plunger heights.
 - The object here is to get as close to the key as possible. A gap of .010" (.25mm) is acceptable but better to kept close as possible.
- B. Set adjusting jig to the calculated plunger length. (See Ill. 112)
 - Adjust all plungers to length.
 - Place the correct sample solenoid plunger into jig.
 - Adjust the bolt to the rubber plunger tip.
 - Adjust all solenoid plungers in the same manor.



Illustration 112 - Jig for adjusting length

In the following pictures dimensions are provided so that you can duplicate this jig that will be used with all future Piano Disc installations. PianoDisc also supplies a Kit with this tool.

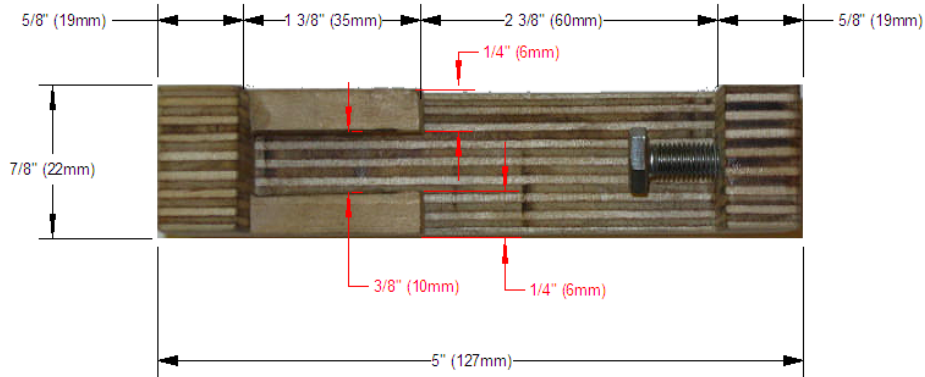

Illustration 113 - Top View

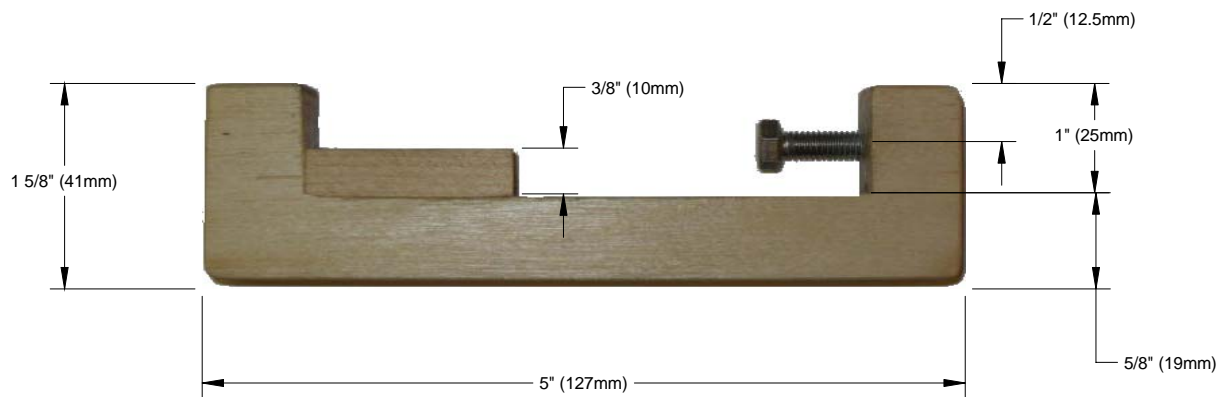
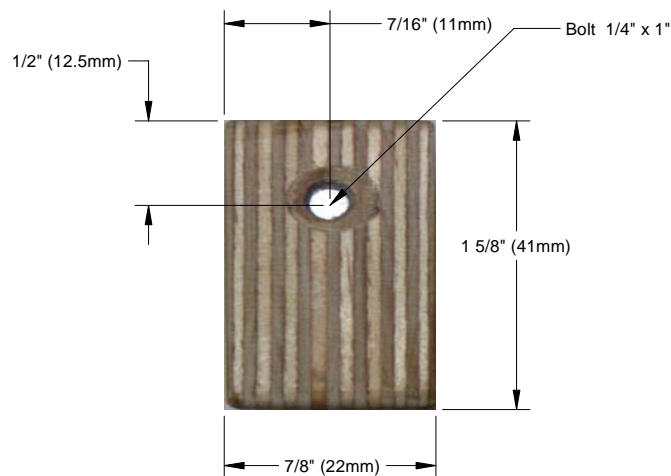

Illustration 114 - Side View



15. Install key solenoids

B. Install the tray end cover plates

- Locate the tray end cover plates in the kit. (See Ill. 116)
 - Place the end cover plates at the end of the tray and center punch the hole locations.
 - Drill a $3/32$ " (2.4mm) hole at the center punch locations.
 - Drill a second hole, $1/8$ " (3.2mm), thru the tray from the outside to clean up metal debris.
 - The $1/8$ " (3.2mm) is just an access hole and the screw will thread into the cover plate.
 - Attach the end plates with the screws supplied. (See Ill. 117)

NOTE: Please see the Addendum 3 on Page 79 at the end of this manual for further instructions on installing the end plates.



Illustration 116 – Tray end cover plate



Illustration 117 – End cover plate installed

C. Install the key solenoid felt.

- Locate the key solenoid felt in the kit.
- Cut the felt the same length as the solenoid rails
- Place the felt on the tray between the rails.
- Locate the sostenuto hole on the felt with a marker.
- Cut the hole in the felt with a hole punch or knife.
- Secure the felt in the tray at each end with contact cement or CA glue. (See Ill. 118)



Illustration 118 – Installing key solenoid felt



Illustration 119 - Mount solenoid pairs on rails

D. Mount the solenoids to the rails.

- Place the correct number of solenoids on each section.
- Install the plungers.
- Place the scale stick on the tray aligning with the end of section solenoids.
- Align and attach all key solenoids.
- Mount the remaining solenoids so that the lowest note in the system is $\frac{1}{2}$ " (13mm) in from the end of the rail.
- Attach the screw to the front rail.
- Set the rest of the solenoid bracket assemblies with plungers on the rails.

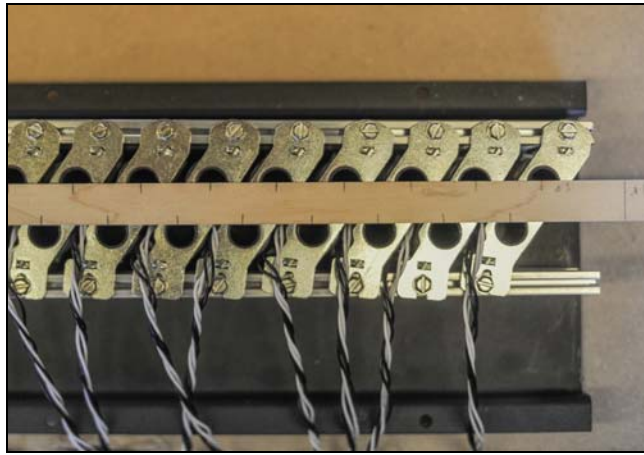

Illustration 120 - Use scale stick to locate solenoids

- Lay the key scale stick between the rows of plunger stems.
 - Move the front and back solenoids so they align with the key end scale stick.
 - Fasten the solenoid bracket to both rails using a hex screw provided for this purpose in the kit.
- **Cut the wires from solenoids that will not be used.**



Illustration 121 - Cutting wires on unused solenoids.

- You will not insert plungers in these solenoids either.

- **Twist the wires from each solenoid**

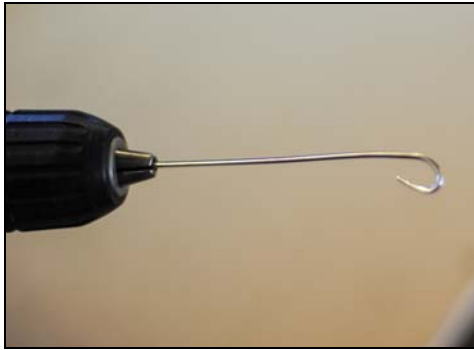

Illustration 122 - Hook in drill



Illustration 123 - Twist solenoid wires

- Take a damper wire and bend a hook in the end of the wire.
- Place the wire in a drill. (See Ill. 122)
- With the hook, twist the solenoid wire 4 full turns for all solenoids. (See Ill. 123)

16. Assemble driver boards to the solenoid tray.

A. Position driver boards for assembly.

- Lay the driver boards on the bench on the appropriate side of the tray.
- The driver boards will mount in the space between the back rail and the edge of the tray.
 - Do not mount the driver boards until after bun-in.

B. Plug solenoids into the driver boards.

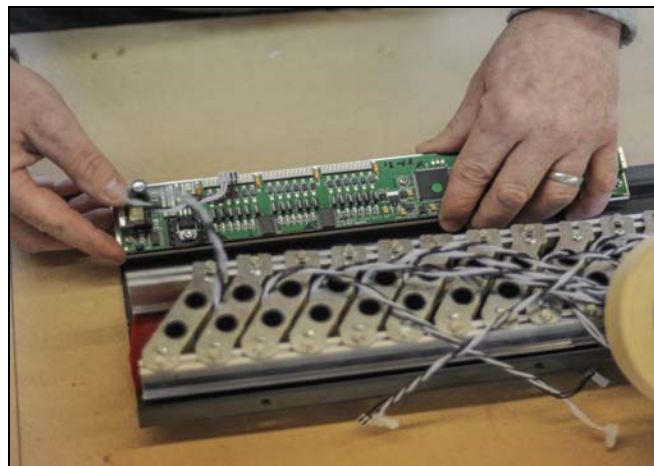

Illustration 124 - Solenoids plugged in

- Remember that if you have omitted solenoids you need to plug the lowest note in the system onto the appropriate pins for that note in the driver board.

- Pay attention in crossing breaks as the color pattern may not be black-white as you have become accustomed to in the past.

C. Connect the data cables between the driver boards.

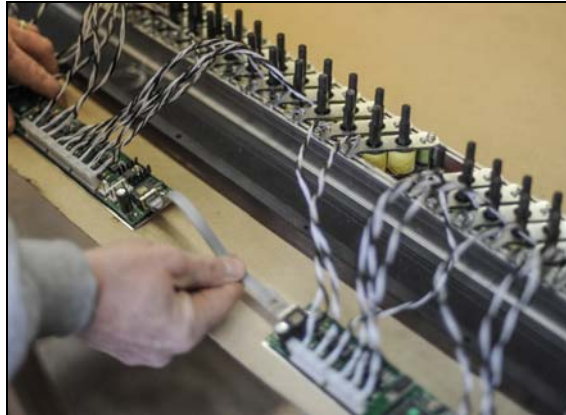

Illustration 125 - Connecting data cables

- The cables that go between the driver boards are gray, relatively short and have RJ-45 connectors.
 - These go between driver boards 1 and 2 and between driver boards 2 and 3.
 - These cables deliver 5 VDC and data to play the music.

D. Connect the Power / Data cable for the sustain pedal solenoid.

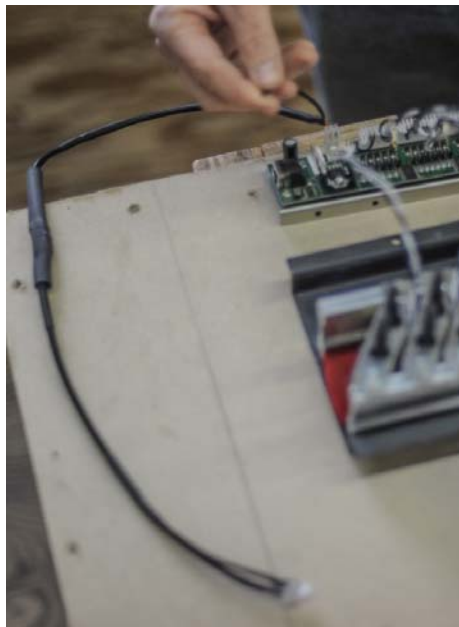

Illustration 126 - Connecting power/data cable for pedal solenoid

- This is an extension cable about 24" long, black with a round connector on one end and a red connector on the other.

- In the case of servicing the system you are able to disconnect this cable on the outside of the belly rail for ease of lowering the solenoid tray.
 - Connect the red connector to the bass driver board. The socket will be right next to the power connector on the driver board.
 - Connect of other end to the pedal solenoid.

E. Connect the 40 Volt power ribbon cable between the boards.

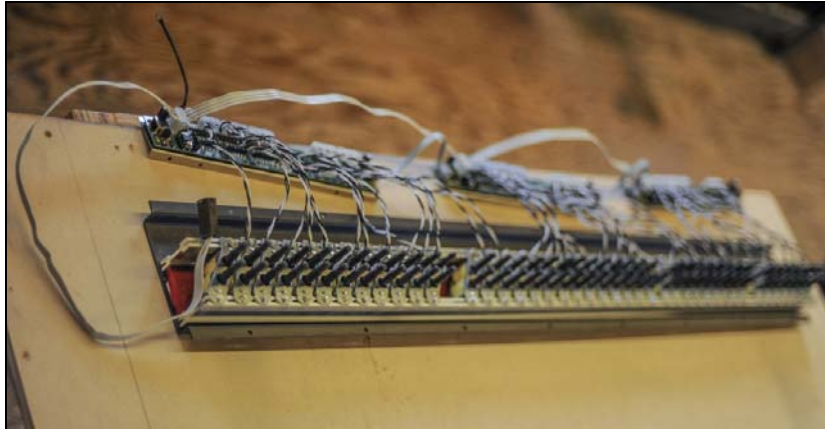

Illustration 127 - connecting 40v cable

- There are three white plugs that go into the driver boards and one black plug that goes to the power supply. This cable supplies the 42 VDC for the key solenoid operation.
 - Plug the end white plug into the treble driver board. (See Ill. 127)
 - Plug the remaining white plus into the tenor and bass driver boards.
 - The remaining black plug will go into the power supply.

17. Setup for burn in.

A. Setup a power supply, an IQ box, and a CPU on the bench.

- These should be close to the tray and solenoid assembly so the cords will reach.



Illustration 128 - Connecting data to CPU



Illustration 129 - Connecting data to iQ box

B. Connect data to the CPU.

- Attach the RJ-45 flat data cable from the bass driver board to the CPU. (see Ill. 128)
 - This is a flat ribbon cable and must be in this position.

C. Connect data to the IQ,

- Connect an RJ-45 data cable from the IQ box to the CPU. (See Ill. 129)
 - This is a round cable and must be in this position.

D. Connect power to the CPU.

- Connect the 10 Volt power cable from the power supply to the CPU.

E. Connect power (40V) to the driver boards.



Illustration 130 - Connecting 40v power to driver boards

- Connect the black plug on the 40 Volt grey ribbon cable into the power supply.

F. Connect power (10V) to the IQ.

- Connect the 10V power to IQ box.

G. Connect power to the power supply.



Illustration 131 – Connecting power to the power supply

- Connect the big power supply cord to power strip.
- Connect the 10V power supply cord to power strip.

18. Burn in the unit.

A. The purpose of burn in is to find and replace any parts that might fail.

NOTE: After burn-in the plunger tips should be re-adjusted if there is any loss motion.

- Use a burn in disc to run the PD system for 24 hours.

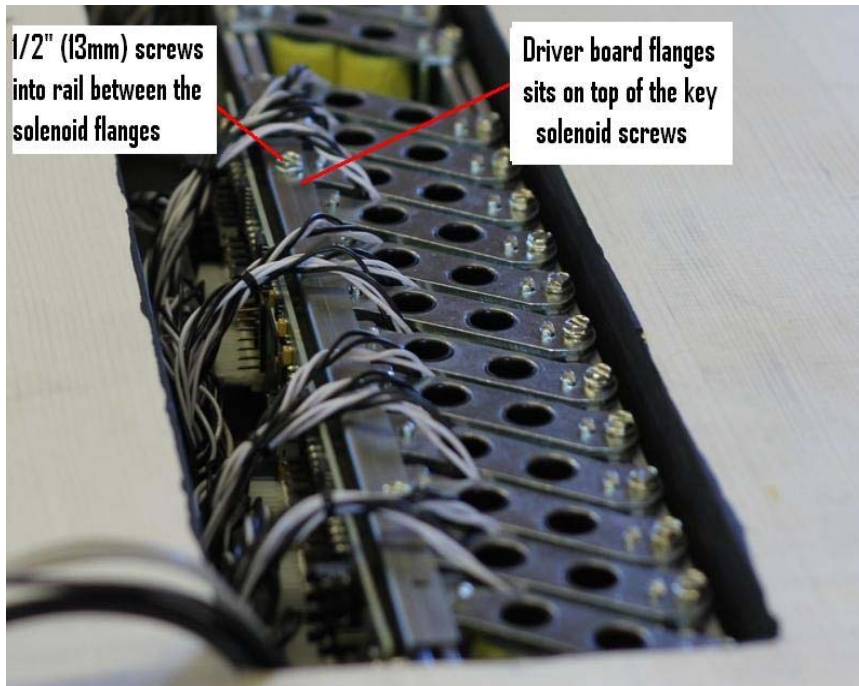

Illustration 132 – Driver boards attached to rail

19. Install driver boards into the tray assembly.

Note: The driver boards are mounted onto the back side of the back solenoid rail. The mounting flange on the driver board bracket has holes that you will position between solenoid brackets. Use two mounting screws, 1/2" (13mm) hexhead, on each driver board into the back solenoid rail to mount. It is possible that you will need to drill an additional mounting hole in the driver board bracket.

A. **Position the Tenor driver board.**

- Position the tenor driver board so that the sustain pitman hole falls in the area where there nothing protruding from the circuit board.
- Make sure that two screws can be used to mount the driver board to the rail between the sostenuto brackets.

B. **Position the bass driver board:**

- If able to position the driver board entirely in the bass section, do so.
- If not possible, position the bass driver board so that the sostenuto hole falls in the area of the circuit board where nothing protrudes.

- Make sure that two screws can be used to mount the driver board to the rail between the sostenuto brackets.
- C. **Position the treble driver board.**
- Position more or less centered on the solenoids connected to the board.
 - Make sure that two screws can be used to mount the driver board to the rail between the sostenuto brackets.
- D. **Attach to the driver boards to the back solenoid rail.**
- Use a longer version of the screws that are used to mount the solenoid brackets to attach the driver boards to the back solenoid rail.
- E. **Rout wires in tray.**
- Rout the data wires.
 - Make sure adequate clearance is maintained and they fit neatly into the slot.
 - Make sure the external data cable is coming out the treble end of the tray assembly.
 - Rout the solenoid wires.
 - Bundle solenoid wires so they are neat and tidy.
 - Make sure the solenoid wires fall in the cut out in the solenoid bracket neatly.
 - Rout the 40V power cable
 - Make sure the cable clears all obstructions.
 - Make sure the black power cord is attached.

20. Drill hole in the belly rail for wires.

- A. **Mark the hole in the belly rail for keyed not removable**
- The center of the hole should be about 2"- 5" in from the end of the slot in the keybed.
 - If notes are left off this hole location will vary. It depends on the bass driver board location.
 - Once the driver boards are attached to the solenoid tray, measure from the end of the tray to the bass driver board and this will be the distance for the hole in the belly rail.
 - Look inside the piano making sure there is nothing in the way of the drilling location.
 - Drill the hole with a 1" (25mm) Forstner bit. (See Ill. 133)

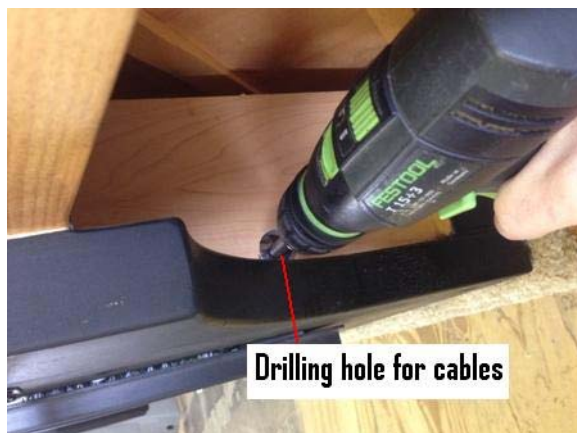

Illustration 133 – Drilling hole in belly rail

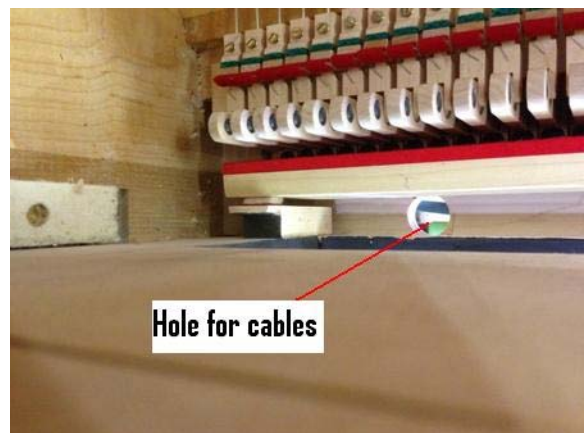

Illustration 134 – Hole in belly rail

21. Mount the CPU.

A. Position the CPU.

- Usually the CPU is mounted on the back side of the belly rail close to the hole you cut in the belly rail to rout wires.
- If the belly rail is not a good location then place the CPU on the side of a beam.

B. Mount the CPU.

- Attach the CPU with the screws provided and include the ground strap under the CPU. (See Ground strap installation – chapter 29)

22. Mount the power supply.

Note: On current PianoDisc units there are two power supplies. The larger power supply provides 40V DC to the driver boards. The smaller power supply provides 10V DC to the CPU and other electronics.



Illustration 135 - 40V Power supply mounted to rim



Illustration 136 – 10V power supply on rim

A. Position the 40V power supply.

- Position the 40V power supply on the rim on the bass side of the piano unless the piano requires you to mount it somewhere else.
- If the piano will not permit then location the 40V power supply as close as possible to the wire holes on some other physical feature of the piano like the rim or a rim strut.

B. Mount the 40V power supply.

- Attach the 40V power supply with the screws provided including the ground strap under the power supply. (See step 30 – Ground strap installation)

C. Position the 10V power supply.

- Position the 10V power supply on a rim strut close to the main power supply.

D. Mount the 10V power supply.

- Attach the 10V power supply with the Velcro provided for this purpose.
 - Place the Velcro at the desired location and secure with 2 staple.
 - Secure each cable with twist ties or zip ties with eyelets supplied in the kit. (See Ill. 136)

23. Mount the power strip.

A. Position the power strip.

- Usually the power strip is mounted on a rim strut of the piano. (See Ill. 139)
- This would imply the power cord for the PianoDisc unit would come down the back leg.



Illustration 137 - power strip mounted to beam

B. Mount the power strip

- Attach the power strip with the 2 screws provided and secure in place with a screw at the end. (See Ill. 139)
 - The end screw will prevent the plug strip from sliding of the mounting screws.

C. Mounting the speakers

- Remove the speakers from the box and locate the mounting hardware.
- Put the speaker on the beam at the selected location ¼" (6mm) from the sound board.
- Mark a line on the speaker at the bottom of the beam.
- Mount the bracket on the appropriate set of screw holes at the side of the speaker. Use the silver self tapping screws supplied to mount the bracket to the speaker.
- Mount the speaker with 2 screws black hex head screws to the beam. (See Ill. 140)
- Place the screw on the side of the speaker near the power switch to stabilize the speaker to the beam. (See Ill. 141)
- Connect the power cable to the speaker and the multi plug strip. Connect the RCA to the speaker and make sure to keep this cable away from the power cable.



Illustration 138 – Speaker mounted to beam

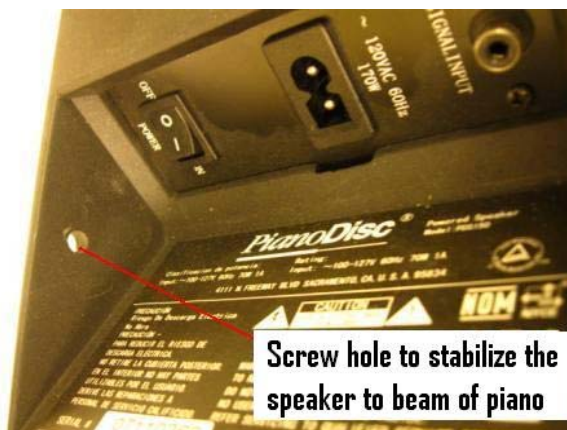

Illustration 139 – Stabilizing speaker to beam

24. Installing keybed to the piano

A. This is a job for 2 people as the keybed gained some weight with the key solenoid assembly attached.

- Place a large piano moving rubber band around the key solenoid plungers to prevent them from falling out while installing the keybed. (See III.)
- Prepare yourself with a rubber mallet close at hand and a clear path.
- Carefully, two people pick up the keybed and place on to the guide pins.
- Use the rubber mallet to tap the keybed into place and secure with the original screws.

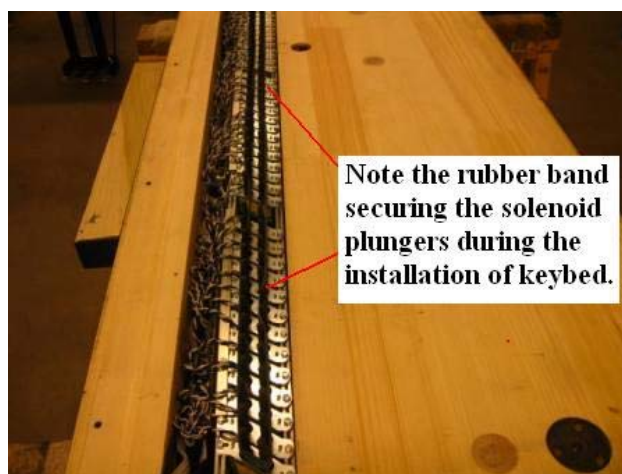

Illustration 140 – Securing key solenoid plunger with rubber band

25. Regulate action.

Note: A PianoDisc system will not perform as it should if the piano is not regulated properly. Since a number of things have been done to the action it is necessary to re-regulate the action even if it was perfect when it arrived.

A. Restore key height to the original settings.

- Bed the keyframe.
 - The front rail should have no knocks.
 - The back rail should be broadly down with no areas up in the air.
 - The glide bolts should be set so that the weight of the keys is supported at the balance rail by the glide bolts.
- Level and dip the keyboard.
 - Use the measurement taken earlier.
 - Reset back key height using cardboard shims under the back rail cloth.
 - Reset front key height by re-leveling the keyboard.
 - Set the front key height to the measurements taken earlier.
 - Set the sharp key height to $\frac{1}{2}$ " (12.7mm) above the white keys after the white keys are leveled.
 - Set key dip as before.

- Usually the white key dip will be between .390" (9.9mm) to .394 (10mm).
 - Regulate notes C-40 & C#-41.
 - Adjust hammer line so you achieve .040" (1mm) after touch with 1/16" (1.6mm) letoff and 1/8" (3.2mm) drop.
 - Set the sharp dip so that the after touch is identical to the white keys.
- Lubricate action with Teflon Powder.
 - Align the hammers to the strings.
 - Align repetitions to the knuckles.
 - Align and square backchecks to the hammer tails.
 - Set initial balancier height so that the jack is flush with the balancier.
 - Set initial hammer line to the dimension needed when setting sharp dip.
 - Regulate jack position in relation to the knuckle.
 - Regulate let-off.
 - Regulate drop.
 - Measure after touch.
 - Put a .040" (1mm) front rail punching on top of the cloth front rail punching.
 - If after touch is .040" (1mm), a weighted touch block will bring the jack to the point of tripping without actually doing so.
 - The slightest additional compression of the front rail punching will result in the jack tripping.
 - If the jack in these circumstances does not trip then there is less than .040" (1mm) after touch
 - If the jacktrips easily then there is more than .040" (1mm) of after touch.
 - If after touch is not to spec, set second hammer line either up or down so that after touch is about .040" (1mm).
 - Check drop and adjust as required.
 - Regulate backchecks for checking.
 - Regulate repetition springs for a controlled rise.
 - Regulate balancier height so the hammer just winks.
 - Clean up hammer line.
 - Clean up drop.

26. Set the height of the adjustable plungers.

Note: In the past the PianoDisc plungers were not adjustable. The tip mounted on the stem in a precise location. A felt pad on the bottom of the tip controlled how far down the plunger sat in the bobbin and thus the stroke of the solenoid. The relationship of the solenoid to the keys was set by moving the mounting rail up or down until the rubber tip of the plunger was as close as possible to the key.

On the Low Profile PianoDisc system the height of the plungers is achieved in an entirely different way. Each plunger has a stem with threads. A plastic nut with a rubber tip adjusts up or down to achieve the proper height. The rail height, unlike previous PianoDisc systems is not adjustable. To adjust the solenoids to the keys you will need a tool similar to a damper under lever height gauge to set the height of the plungers.

A. On the bench

- Place all key on the keyframe and attach the top action.
- Place the tray assembly into place on the keybed with all screws attached.
- Locate the keyframe at correct location on the keybed.
- Adjust the heights of the plungers to the bottom of the keys.
- The plunger tip should be as close to the key as possible not have more that .004" (.1mm) gap.

B. In the piano

- Measure the back key heights.
 - Use a damper under lever height gauge to measure the back key height.
 - Set the action on a flat bench.
 - Measure the back key height so that the gauge matches the bottom of key.
- Set the plunger heights.
 - Set the damper height gauge on the keybed.
 - Use a damper under lever height gauge to set the plunger height.
 - Hold the gauge over the plungers to see the amount of adjustment necessary.
 - Lift the plunger out of the solenoid and turn the Plastic nut until the rubber tip just touches the damper height gauge.
 - Place the action into the piano and verify there is a straight hammer line.

27. Set up communication with the PianoDisc system.

Note: Older PianoDisc units featured a control box that used floppy disks or CDs. If you have one of these in your shop it can still be useful for communicating with the PianoDisc unit for the purpose of configuration.

If not, you will need to setup communications with the PianoDisc unit and use iPhone or iPad to run the configuration suites. If the unit is shipped with an AirPort Express, that is straight forward. If not, you can plug your iPhone or iPad directly into the control box in order to configure the PianoDisc unit.

A. Setup communications with the PD system in order to configure.

- Plug in either a 128 or 228 control box.
- Setup AirPort Express.
- Plug an iPhone or iPad that has the configuration suite installed into the CPU.

28. Adjust the pedal solenoid.

Note: Adjust the stroke of the pedal solenoid so that dampers are lifted off the string 1/16" (1.6mm). There may be times when, as a result of poor regulation or worn parts, the stroke in the pedal solenoid must be set longer. The shorter the stroke on the pedal solenoid the less heat will develop. Less heat in the solenoid translates to a longer life for the pedal solenoid.

In the bichord and trichord notes, the pedal solenoid should be set so that the wedges do not clear the strings. The felt wedge should be between the strings but not touching either.

The least amount of travel for sustain to occur is the correct setting for the pedal solenoid.

A. Go over sustain damper lift to the pedal.

- Test to see if all dampers are lifted off the strings at the same time.
 - Lift all dampers with the sustain pedal.
 - Using the back of your finger nail get all the strings in the piano vibrating.
 - Lower the dampers slowly with the sustain pedal.
 - If the sound stops on all notes at the same time your damper pickup is regulated properly.
 - If the action is out of the piano you can watch the pickup to see if they pick up together.
- If the damper lift needs adjustment.
 - Get a low stool to sit on.
 - Use the sustain pedal to move the damper tray from at rest to pick up.
 - You can see the ones that are not lifting with the others.
 - Adjust the damper lever pick up in whatever way is required by the design of this particular damper action.
 - On Steinways and a number of old pianos you will need to place shims (usually balance rail punchings) between the pickup felt and the tray.
 - On most other pianos there will be a capstan or other screw adjustment to alter the damper pickup.

B. Adjust the pedal rod for minimal free play between the damper tray and the underlever.

- Use the appropriate wrenches to loosen the lock nut on the sustain pedal rod.
- Adjust the long cap nut up or down until there is minimal travel before the dampers start to lift off the strings.
 - You may find it necessary to adjust the pickup of the dampers if they are not currently lifting evenly.

C. Adjust pedal solenoid stop pad.

Note: The stop pad is circular felt pad that limits the pedal solenoids return distance. It is with a threaded rod going through the bracket so as to control the stroke of the pedal solenoid. A lock nut holds the adjustment so that it will not change in use.

When the pedal solenoid is mounted in the piano and the piano is on the floor, the felt pad is on the “top” side of the solenoid. The large hex thrust nut is on the bottom of the solenoid.

- Loosen lock nut with the appropriate wrench.
- Turn the pedal solenoid stop pad in a clockwise direction (looking from the bottom) until it is as high as it will go.

D. Adjust the pedal solenoid hexagonal thrust nut up out of the way.

- Loosen lock nut with the appropriate wrench.
- Turn the hexagonal tip up as far as it will go so it is out of the way.

E. Adjust the sustain pedal solenoid.

- Load Damper Test (song 2) and press play.
 - Song repeat can be set for continual repeat.
- Observe the wedge damper lift.

- Adjust the damper lift.
 - Turn the Hex Thrust nut (3/4" (19mm)) to adjust damper lift.
 - From the bottom, counter clockwise will get you more lift.
 - Clockwise will get you less lift.
 - When lift is correct tighten the 9/16" (14mm) lock nut.
- Adjust loose motion in the pedal solenoid.
 - Rotate the large steel washer with the felt pad until there is only 1/16" (1.6mm) of loose motion.
 - When correct tighten the lock nut on the top of the pedal solenoid.

29. Final check list.

A. Play test disk.

- Verify that all solenoids, keys and pedals are functioning properly.
- Verify that all functions of the controller and the remote control are functioning properly.

B. Secure and neatly arrange all cables and cords to the beams with the proper fasteners.

C. Check the components to ensure that they are securely installed.

- Power supply.
- Driver boards.
- Solenoid rails.
- Pedal solenoid (ensure that lock nuts are tight).

D. Check the solenoids to ensure that all of the hammers are in the rest position.

E. Repeat the playing of the test disc, the note to note portion, and check for the proper playing of the piano.

- Operate the system for at least 12 hours continuously.
- Recheck the piano and the PianoDisc system for proper operation after 12 hours of burn in.

30. Ground Strap Installation

ESD Strap Installation – Grand Pianos Low Profile System

There are 2 ESD straps that are included with the kit.

1. The #1 is an 18" strap should be attached from the bottom side of the power supply where it is screwed to the rim, then thru the belly rail hole to the key solenoid rail.

Note: There's a location on the under side of the power supply that has exposed metal. Please make sure that the ESD strap makes contacted with the surface that is exposed.

2. The #2 is a 36" strap that attaches to the #1 strap with a small screw (as shown), and the other end should attach to the under side of the CPU. Please refer to the following illustration.

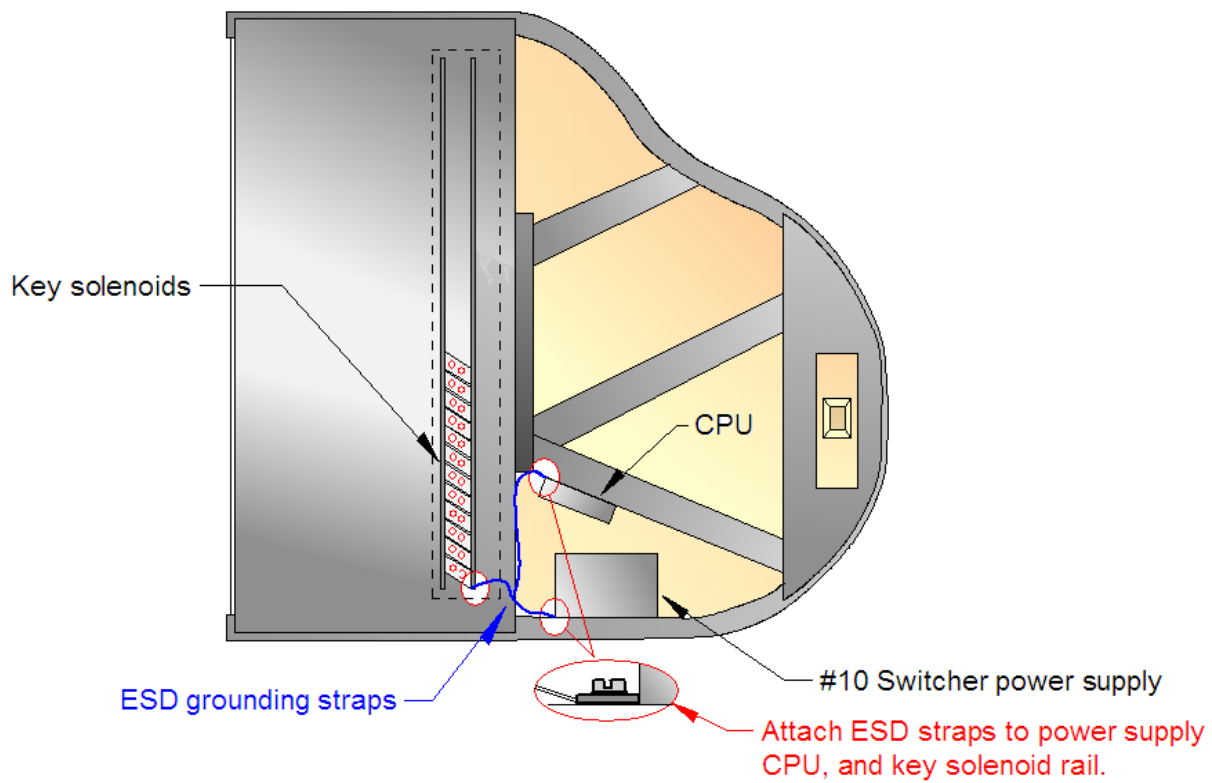

Illustration 141 – ESD ground strap locations

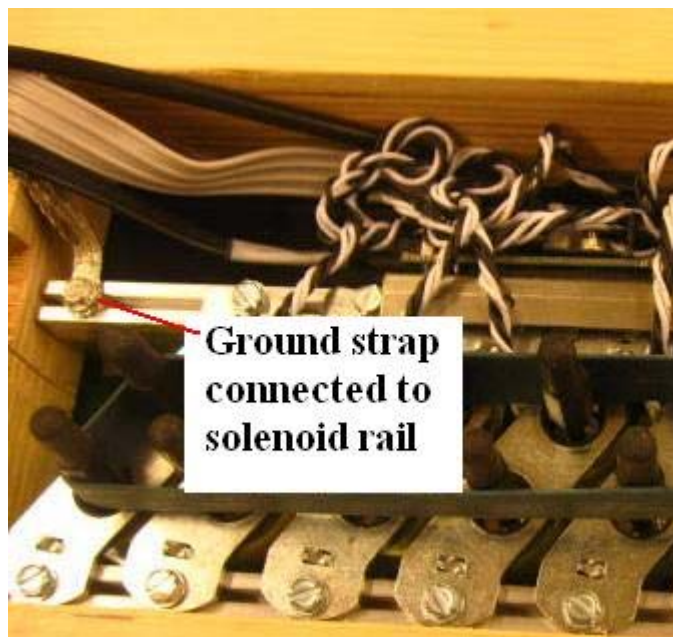

Illustration 142 - ESD ground strap to solenoid rail- bass end

Addendum 1 - Steinway Sostenuto

The American Steinway sostenuto is different than most other pianos because they mount the sostenuto on the top action instead of the belly rail. Also they use the keybed to guide a dowel that contacts a wooden linkage called a “monkey”. Since the cutting of the keybed removes this guide hole we must find another guide. See the following steps in how we create a new guide.

A. Preparing the Steinway sostenuto guide

- Place a mark for the location of the sostenuto on the scale stick. (See Ill. 1)



Illustration 1 – Location for sostenuto monkey.

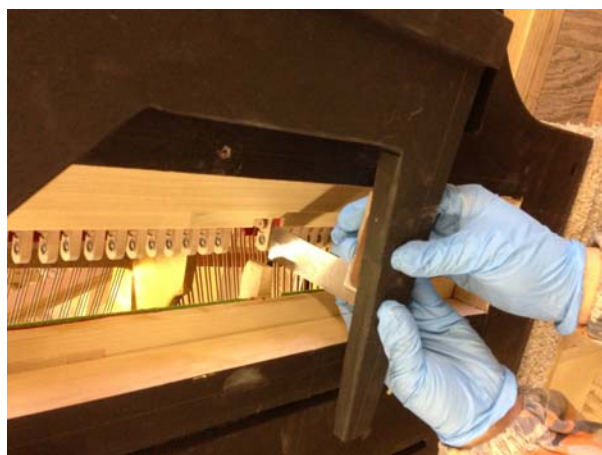

Illustration 2 – Locating the pitman to lever

- With the trapwork lever in the correct position, use a square and mark the location for the pitman rod to contact the lever. (See Ill. 2 & 3.)



Illustration 3 – Locating the pitman to lever

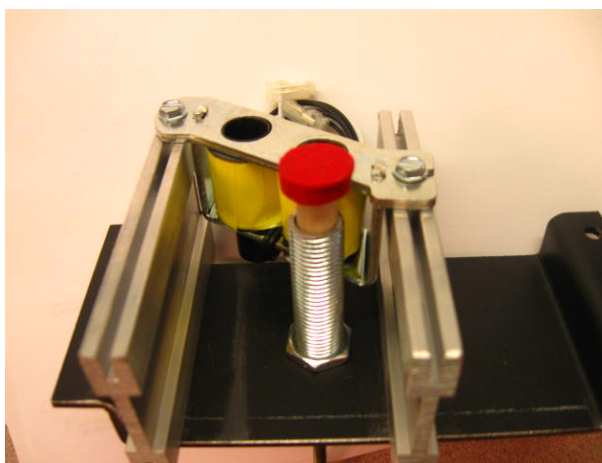

Illustration 4 – Placement of sost. Guide in rail

- Parts needed for this assembly that are not supplied in the kit (See Ill. 5)
 - 1 - Threaded rod (tube) – ¼”(6mm)x2”(50mm)
 - This thin wall threaded rod can be found in the lighting section of Lowe’s, Home Depot or hardware store.
 - 2 - Lock nuts for the threaded rod
 - 1 – Wood dowel – 3/8”(9.5mm) x 2”(50mm)
 - 1 – Felt punching – ½” (13mm x 3/16” (5mm). The thickness of the felt doesn’t matter.
 - 1 – Piece of thin wood or veneer.
- This assembly will be placed into the solenoid tray at the break to activate the monkey. (See Ill. 4 & 6)

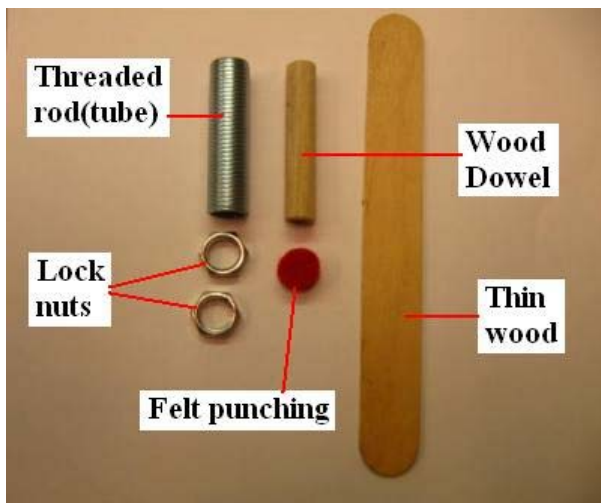

Illustration 5 – Parts needed for guide

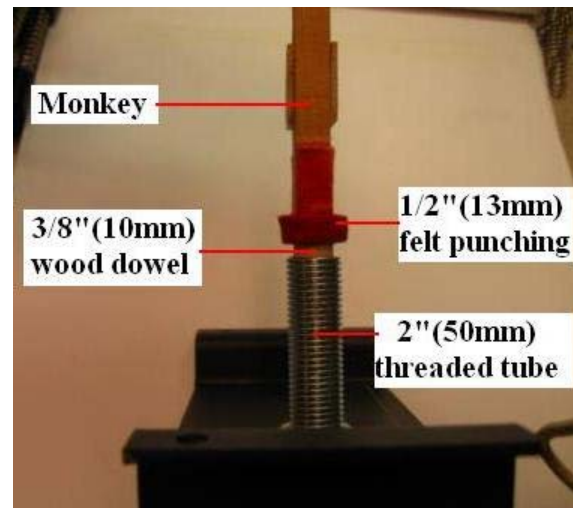

Illustration 6 – Mock-up of sostenuto

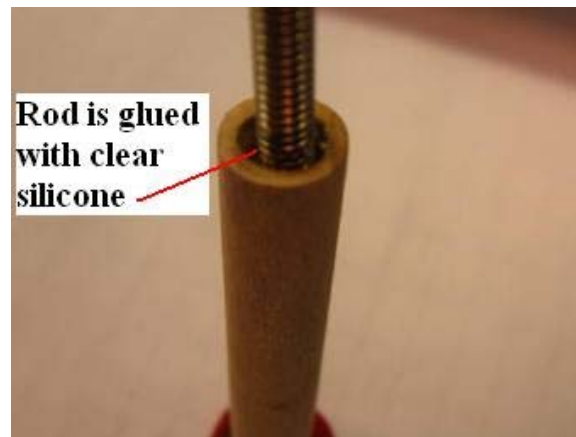

Illustration 7 & 8 – Pitman rod glued into dowel

- Drill a 3/16”(4.7mm) hole ½”(13mm) deep into one end of the 3/8”(6mm) wood dowel.
- Glue the threaded rod (supplied in kit) into the hole with silicone glue. (See Ill. 7 & 8)
 - Only glue into the bottom half of the hole so the rod can pivot easily.
 - This assembly works very nicely as it has some give side to side to keep from binding.
- Now glue the ½”(13mm) felt to the end of the dowel for a soft and larger area. (See Ill. 4 & 6)

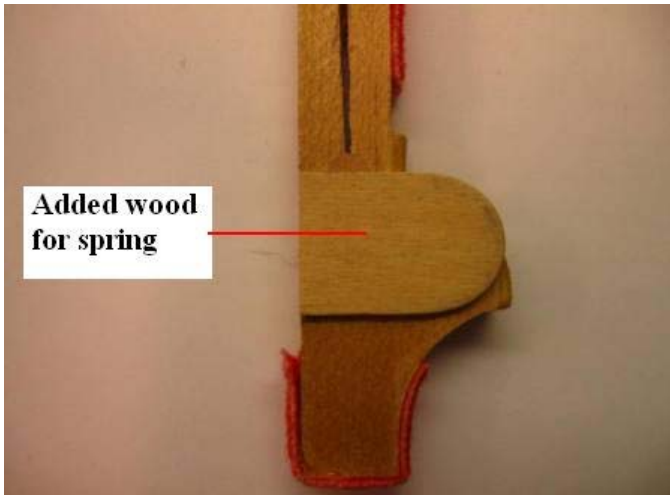

Illustration 9 & 10 – Placing wood on monkey

- Glue on thin wood or veneer to the sides of the monkey to secure the spring. (See Ill. 9 & 10)
 - Because the guides for the monkey were removed from the cutting of the slot this is a simple method of controlling the spring and position of the monkey.
- Cut the threaded rod (tube) to 2”(50mm) in length and clean off the burrs. (See Ill. 11)
 - Roll up a piece of 220 sand paper and smooth any burrs on the inside of the threaded rod.
 - Test the 3/8”(6mm) dowel for fit after cleaning off the inside of the threaded rod.
 - Install the threaded rod (tube) into the 1” punched hole and secure with the 2 lock nut.

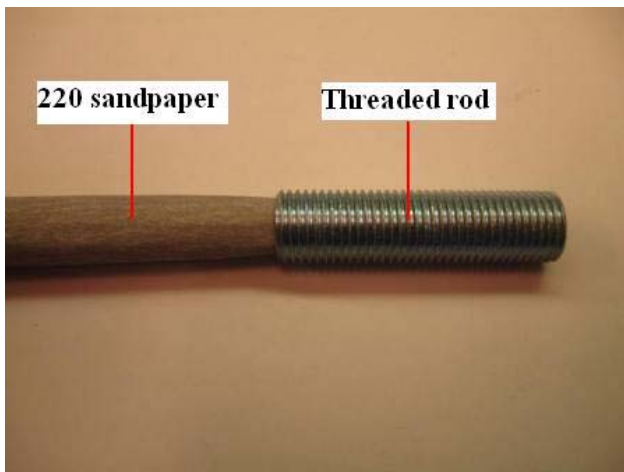

Illustration 11 – Sanding threaded rod



Illustration 12 – Replacing the cut out of the keys

B. Modify the keys

- Because of the guides for the monkey, the key were cut away at the bottom. This wood must be replaced for the key solenoids.
 - Use some scrap soft wood to glue on the keys.
 - Glue pieces of wood on the keys keeping the grain running the same direction. (See Ill. 12)
 - After glue is dry, dress down the keys forming the original shape of the keys.

Addendum 2 - Keyframe modifications/Shift lever

Because of the moving forward of the shift lever it is necessary to move the hardwood contact point on the keyframe. (See Ill. 1 & 2)

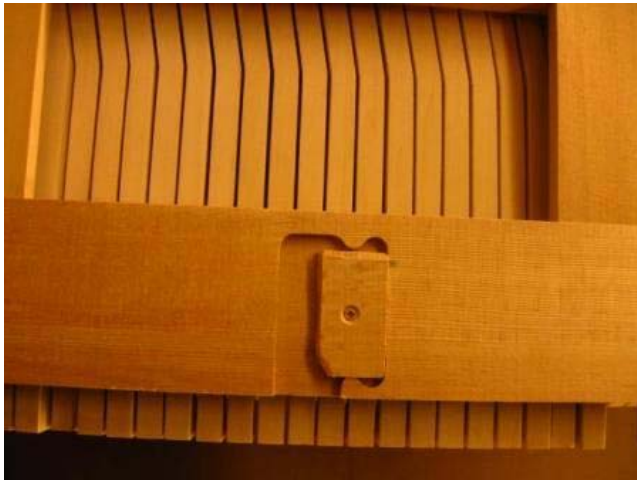

Illustration 1 – Before keyframe modification

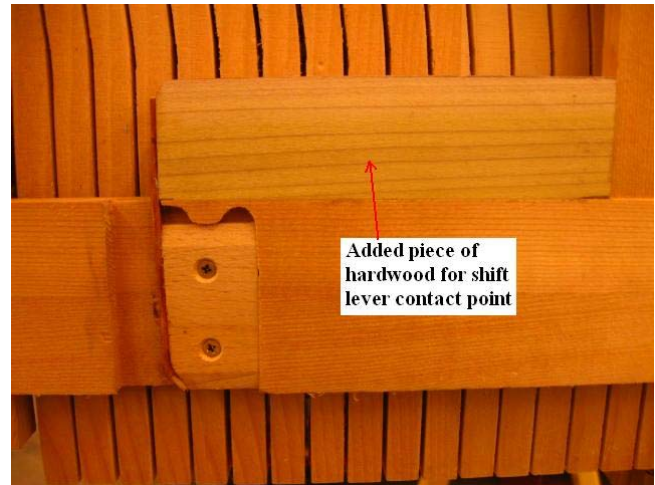

Illustration 2 – After adding hardwood

Addendum 3 - Clearance for end plates

Because of the design of the end plates it is necessary to cut a clearance on the end of each rail. See Ill. 1.

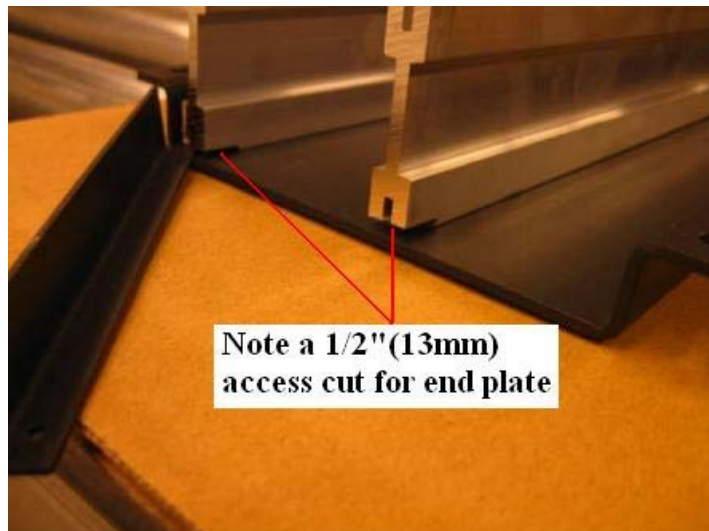

Illustration 1 – End plate access

